

## A general overview of Irabu Ryukyuan, a Southern Ryukyuan language of the Japonic language group

Shimoji, Michinori

Research School of Pacific and Asian Studies, Australian National University

<https://hdl.handle.net/2324/7342425>

---

出版情報：思言：東京外国語大学記述言語学論集. 1, pp.31-65, 2006-03-31. 東京外国語大学地域文化  
研究科・外国語学部記述言語学研究室

バージョン：

権利関係：



# *A general overview of Irabu Ryukyuan, a Southern Ryukyuan language of the Japonic language group<sup>1</sup>*

Michinori Shimoji

**Key words:** Irabu Ryukyuan, Ryukyuan, Japonic languages, Japanese, grammar

## 1. Language and its speakers

### 1.1. Geography and Genealogy

Irabu Ryukyuan is spoken on Irabu Island, one of the islands in the southern extreme of Japan, which are collectively called the Ryukyu Islands (Map 1). Within the Ryukyu Islands, Irabu Island is among a group of islands called the Sakishima Islands (Map 2), specifically Miyako Island group (Map 3).

All the languages and dialects of the Ryukyu Islands form a major subgroup of the Japonic language group (Figure 1). This subgroup is collectively called Ryukyuan. Ryukyuan itself falls into two lower-order subgroups, Northern Ryukyuan and Southern Ryukyuan. These two subgroups in turn have a number of divisions.

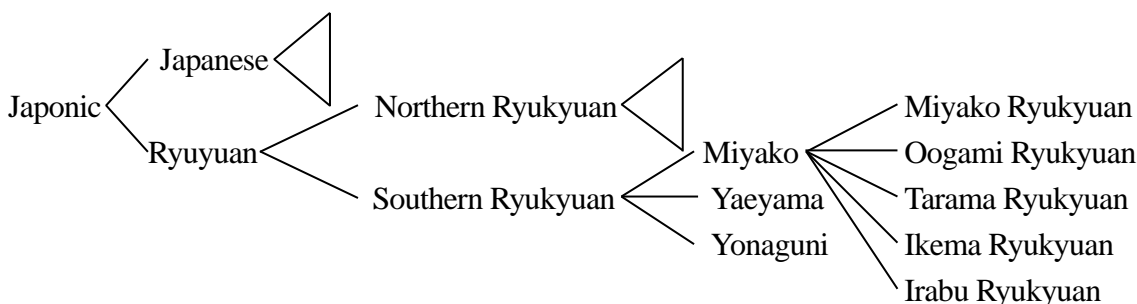
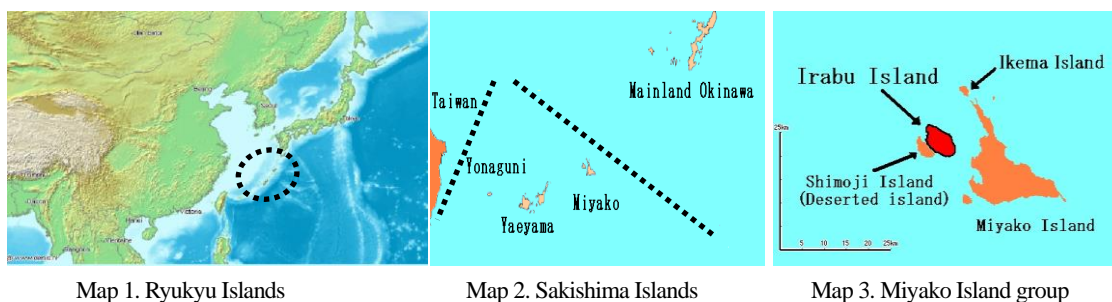

Figure 1. Japonic language group (cf. Kamei, Koono, and Chino, eds. 1997)

<sup>1</sup> This is a mid-term report of my ongoing fieldwork (Nov. 2005-May.2006), which is part of my PhD project “a grammar description of Irabu Ryukyuan”.

## **1.2. Previous studies on Irabu Ryukyuan**

The main focus of the previous studies on Irabu Ryukyuan has been on the phonetic/phonological aspects of that language. Two short phonological studies have been published on Irabu Ryukyuan (Motonaga 1982, Nakama 1983). An extensive list of basic words with phonological descriptions has been published by a group of students of the University of Ryukyus (Ryuukyuu hoogen kenkyuu kurabu 2004, 2005). Besides, a phonetic/ phonological study on Irabu Ryukyuan has been published where phonetic aspects and their phonological interpretations were discussed in some length (Sawaki 2000)

Attempts to describe the grammatical aspects of Irabu Ryukyuan, on the other hand, are still beyond the horizon. No reference grammar of Irabu Ryukyuan has ever been published.

Though there has been no dictionary available for Irabu Ryukyuan so far, a project is in progress in which the first dictionary of Irabu Ryukyuan (specifically Irabu-Nakachi dialect, see 1.3.3) is being compiled (Karimata, Shigehisa, p.c.). A short text material is available (Shibata 1972).

## **1.3. Sociolinguistic overview**

### **1.3.1. Media and education**

There is no local media on Irabu Island. Newspapers, television programs, and radio programs are broadcasted in Japanese, which is the national language of Japan, and is basically the single medium of education in Japan. Irabu Ryukyuan is not taught in schools.

### **1.3.2. Viability**

Irabu Ryukyuan is in imminent danger of extinction. That is, in ten to twenty years, the language would be completely out of use, and give way to Japanese. Though many elders (70's and older) have sufficient fluency of Irabu Ryukyuan, the situation is very different in the younger generations. Some of 50's and 60's have a perfect fluency of the language, while others are almost passively bilingual. Still younger generations (20-30's and younger) tend to have a very limited command of Irabu Ryukyuan (e.g. lexical knowledge).

### **1.3.3. Dialects and the number of speakers**

There are four distinct dialects found on Irabu Island: Sawada-Nagahama dialect, Kuninaka dialect, Irabu-Nakachi dialect, and Sarahama dialect (see Map 4). The first three belong to Irabu Ryukyuan, while Sarahama dialect is arguably a member of Ikema Ryukyuan rather than Irabu Ryukyuan, though both are daughter languages of the same sub-division of Ryukyuan (see Figure 2).

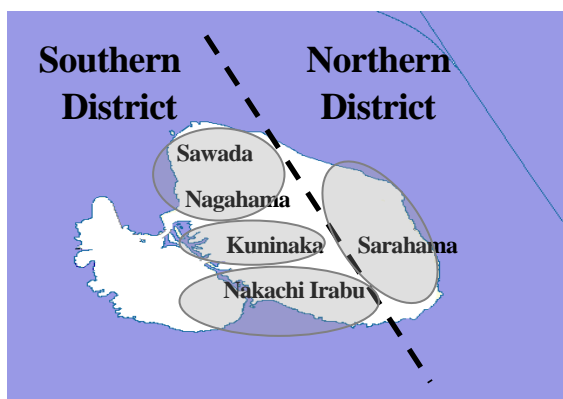

Map 4. Dialects on Irabu island

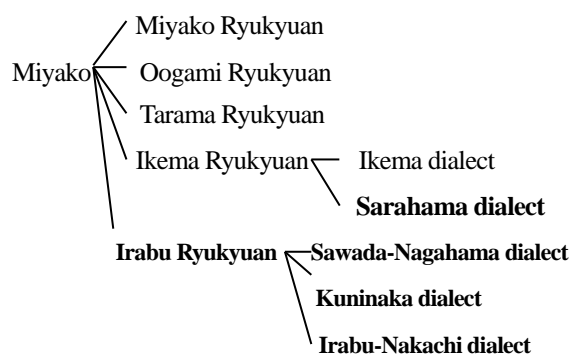

Figure 2. Dialects and genealogy

Sawada-Nagahama dialect is spoken in Sawada area and Nagahama area (henceforth Sawada-Nagahama area). Irabu-Nakachi dialect is spoken in Irabu area and Nakachi area (Irabu-Nakachi area). Between Sawada-Nagahama area and Irabu-Nakachi area is Kuningaka area. Kuningaka dialect is closer to Sawada-Nagahama dialect than to Irabu-Nakachi dialect (Motonaga 1982).

As is presented in Map 4, the first three dialects of Irabu Ryukyuan are spoken on the Southern District (a population of **2,970** in 2004), while Sarahama dialect is spoken on the Northern District (**3,690** in 2004)<sup>2</sup>. There is a high degree of mutual intelligibility among these four dialects across genealogical membership, though local people are well aware of the dialectal differences among them. The differences are mainly phonological and lexical.

Below I will sketch out a grammar of Irabu Ryukyuan with a particular focus on Sawada-Nagahama dialect, unless otherwise specified.

## 2. Phonology

### 2.1. Segmental phonology

#### 2.1.1. Introduction

The inventory of the phonemes of Irabu Ryukyuan is presented in the following table.

Table 1. Phonemes of Irabu Ryukyuan (the allophones in squared brackets are typical ones of a given phoneme)

	Phonemes
Consonant	p, b, t, d, k, g, ts, dz, m, n, r [r/ɺ] <sup>3</sup> , f, v, s, (z), (h), w, y
Vowel	a, i, I [ɨ/ɨ̃/ɨ̄], u [u~u] (e), (o)

<sup>2</sup> The demographic information is based on [http://www.rik.ne.jp/town-irabu/pages/ko\\_jinko.html](http://www.rik.ne.jp/town-irabu/pages/ko_jinko.html) (last cited date: 25/10/2005)

<sup>3</sup> A/B indicates that A and B are allophones of particular environments, while A~B indicates that A and B are free variations. See ABBREVIATIONS at the end of this paper for the full list of abbreviations and symbols.

As presented in the table above, I set 24 phonemes for Irabu Ryukyuan. The bracketed phonemes /z/, /h/, /e/, and /o/ are very limited in frequency and distribution, as will be described in the following sections. Long vowels (e.g. [a:]) and long consonants (e.g. [m:]) are phonologically analyzed as two vowel/consonant sequences (e.g. /aa/ and /mm/).

### 2.1.2. Consonants

/p/, /t/, and /k/ can open the syllable (CV) and close the syllable (VC), though these phonemes cannot appear word-finally (\*VC#). /p/ has allophones [p<sup>h</sup>] and [p]. The former tends to appear when /p/ is word-initial and inter-vocalic (/VpV/). Otherwise the latter tends to appear. This distributional tendency also holds for /t/ ([t<sup>h</sup>] and [t]) and /k/ ([k<sup>h</sup>] and [k]).

- (1) *kata* [k<sup>h</sup>at<sup>h</sup>a] ‘shoulder’      (2) *pana* [p<sup>h</sup>ana] ‘nose’

/ts/ is realized as [tʃ] when it precedes /i/. Otherwise it is realized as [ts]. Likewise /dz/ has allophones of [dʒ] and [dz]. /ts/ and /dz/ can open the syllable and close the syllable. /dz/ tends to be pronounced as [dz] rather than [z] even in the inter-vocalic position.

/b/, /d/, and /g/ function almost exclusively as syllable-opening consonants. They do not appear in the syllable-final position<sup>4</sup>.

/m/, /n/, /r/, /f/, /v/, and /s/ are multi-functional in terms of the syllable structure. They open the syllable (CV), close the syllable (VC), or serve as the syllable nucleus (C)<sup>5</sup>.

- (3) *maI* [maʔ]~[maŋ] ‘rice’      (4) *kam* [kam] ‘god’      (5) *mta* [mta] ‘mud’  
 (6) *nada* [nada] ‘tears’      (7) *kan* [kaŋ] ‘crab’      (8) *ndza* [ndza] ‘where’  
 (9) *pari* [pari] ‘go’      (10) *par* [pa] ‘needle’      (11) *prma* [pɽma] ‘daytime’

<sup>4</sup> For example, /dd/ as in *kuuddya* ‘please come’ is analyzed as the syllable onset consonant cluster (/kuu.ddya/). This is based on other syllable onset consonant clusters /ff/, /vv/, /ss/, etc., and the fact that if /kuuddya/ is interpreted as /kuud.dya/, we would have to admit a non-canonical syllable structure CVVC.

<sup>5</sup> Here I am tentatively defining the notion syllable as a unit which carries or may carry a phonetic accent and intensity, and always sustains one mora.

(12) *faumunu* [faumonu] ‘food’ (13) *kaf* [kaf]~[kaf<sup>6</sup>] ‘write’ (14) *ffa* [ffa] ‘child’

(15) *avva* [avva] ‘oil’ (16) *pav* [pav]~[pav] ‘snake’ (17) *vva* [vva]~[vva] ‘thou’

(18) *sanaka* [sanaka] ‘late morning’ (19) *as* [as]~[as<sup>1</sup>] ‘do’ (20) *ssan* [ssaŋ] ‘not know’

/m/ is a non-homorganic nasal even when it precedes a consonant, while /n/, when it precedes a consonant, becomes homorganic.

(21) *mta* [m̥ta] ‘mud’ (22) *mna* [m̥na] ‘shellfish’ (23) *mssuu* [m̥<sup>p</sup>ssu:] ‘miso soup’

(24) *tin* [tin]~[tiŋ] ‘sky’ (25) *tin+pav* [tim̥pav] ‘rainbow’ (26) *tin-gami* [tiŋgami] ‘to the sky’

It is noted, however, that /m/ is losing its non-homorganic characteristic, even among the elder speakers (*mtsI*~*ntsI* [m̥tsɪ]~[ntsɪ] ‘road’).

When /n/ is in the word-final position with no other element following it (e.g. pronounced in isolation), it tends to be realized as [n] when V is /i/ and /I/, while it tends to be realized as [ŋ] when V is /a/ and /u/.<sup>7</sup> When /n/ is followed by C, it becomes homorganic.

/n/→[n]/\_(S)V (27) *nudu* [nudu] ‘neck’ (28) *nyaan* [nja:ŋ]<sup>8</sup> ‘not exist’

[n]/V<sub>[+Front +High]\_#</sub> (29) *sin* [ʃin] ‘line’ (30) *sI-n* [sɪn] ‘die’

[ŋ]/V<sub>[-Front]\_#</sub> (31) *kan* [kaŋ] ‘crab’ (32) *sakun* [sakuŋ] ‘soap’

[homorganic]/\_C (33) *kan=mai* [kammai] ‘crab as well’

/r/ includes [r] and [ʀ]. [ʀ] appears before a consonant and syllable-finally while [r]

doesn’t. /rrV/ is always [ʀV] where the former /r/ is realized as [ʀ], to which the latter /r/

<sup>6</sup> The word-final /f/ may carry the voiced off-glide [v] (or [ʋ]). This is not a “vowel phoneme”. That is, this off-glide is not a phonemic entity, but a phonetic one.

<sup>7</sup> This is truer for very old speakers (80’s and older) than for younger speakers. One of my consultants, aged 68, did not have [n] word-finally, and always pronounced [ŋ] in the word-final position irrespective of the preceding vowel.

<sup>8</sup> [n] as in *nyaan* is more accurately [ŋ]. However, in this study I do not distinguish these two, since the phonetic difference of relevance concerned with /n/ is that of the bilabial ([m]), the alveolar ([n]) and the velar ([ŋ]).

assimilates, as in /yarruu/ [ja[u]:] '(comparative case)'. There seems to be a strong constraint that /r/ cannot appear word-initially. In my list of 2,000 basic words, there is only one attestation of the word-initial /r/ (*rintsI* [rintsɿ] 'jealous').

/f/ includes [f] and [ϕ] as free variations. Likewise, /v/ includes [v] and [ʋ] as free variations. /v/ tends to be realized as [v] if it is followed by another /v/ (*vva* [vva] 'thou'). Also, when /v/ is preceded by a vowel, it tends to be realized as [ʋ] (*pav* [pav] 'snake').

/s/ is realized as [ʃ] if it precedes /i/. Otherwise it is realized as [s].

/z/ ([z] and [ʒ]) has no morphophonemic independence, only occurring with morphological processes. It occurs when a morpheme ending with /l/ [<sup>z/a</sup>l] is affixed by a morpheme beginning with a vowel phoneme. Thus *bl-I* [b<sup>z</sup>ɿ:] 'sit (indicative non-past)' becomes *biz-i* [biʒ-i] 'sit (imperative attemporal)'. The phonological analysis on /z/ remains to be further elaborated. An alternative analysis would be to assume that the [ʒ] as in *biz-i* is an allophone of /l/, though this solution has several problems, too.

/h/ is the most restricted consonant phoneme in terms both of frequency and distribution. It can be found in a very few words such as *hatto* [hatto] 'I'm ready! (used when responding to the person who is about to start telling a fable or an old story)' and *nkyagihamatsi* [ŋkjagihamatʃi] 'please eat'. In my list of 2,000 basic words, /h/ precedes /a/ and /i/ but not /l/ and /u/.

In a very few words, glottalized consonants ([<sup>ʔ</sup>t], [<sup>ʔ</sup>ts] and [<sup>ʔ</sup>tʃ]) are observed, especially in the word-initial position. Although such glottalized phones seem to be limited in distribution (lexicalized), it is still possible to find minimal pairs contrasting in glottalization ([<sup>ʔ</sup>ta] 'drip' vs. [<sup>ʔ</sup>ta] 'came'). I do not set up a glottalized phoneme /<sup>ʔ</sup>ts/ at this stage, but interpret these glottalized phones as word-initial consonant clusters #/tt/ and #/tts/. For

example, [ʔtʃi] ('cigar pipe (noun)/ wear (verb)') is interpreted as *ttsir*. This analysis is supported by 1) the existence of other word-initial consonant clusters #/mm/, #/nn/, #/ff/, #/vv/, #/ss/, and #/rr/, and 2) the morphological consistency that verbs carrying the glottalized consonant and verbs carrying these word-initial consonant clusters show parallel conjugational patterns.<sup>9</sup> Also, it is noted that there is a morphophonological alternation where the glottalized phones may alternate with genuine consonant clusters ([ʔtʃi] 'cigar pipe' → [akattʰʃi] 'red cigar pipe'). Note here that while the glottalized phone [ʔtʃ] is (by its very nature) never aspirated, it alternates with a slightly aspirated sound [tʰʃ] when preceded by another morpheme in compounding.

### 2.1.3. Vowels

Irabu Ryukyuan has six vowels. The short vowels /e/ and /o/ are quite rarely found in basic words, but relatively frequently found in loan words. On the other hand, the long vowels /ee/ and /oo/ are relatively frequently found in basic words (*ee* 'yes (informal)'; *oo* 'yes (formal)').

/u/ includes [u] and [ʊ], which are (at this stage) analyzed as free variations in the sense that they can occur in the same environment without a change in meaning (e.g. *katamusI* [katamusʏ]~[katamusʊ]'shoulder').

/l/ includes [l], [ɭ], and [ɮ]. These are pronounced with the tongue ridge very close to the alveolar, to the extent that a fricative sound similar to [s]/[z] may appear as an on-glide.

/l/ → [ɭ]/C<sub>[-alveolar][+voiced]</sub>\_ (34) *yubI-I* [jubʷɭ:] 'suck'

V\_ (35) *a-I* [aʷɭ]~[aɭ] 'say'

[ɮ]/C<sub>[-alveolar][-voiced]</sub>\_ (36) *pIdar* [pʷɮda] 'left' (37) *pItu* [pʷɮtu] 'human'

[l]/C<sub>[+alveolar]</sub>\_ (38) *sIba* [sɭba] 'lip' (39) *tsIn* [tsɭn] 'cloth'

<sup>9</sup> For example, the word meaning 'wear' conjugates for *tts-a-n* [ʔʰsaŋ] 'not wear' (irrealis negative non-past), *tts-i* [ʔʰʃi] (imperative attemporal), and *tsI-I* [tsɭ:] (realis finitive non-past), etc. The word meaning 'bite' conjugates for *ff-a-n* [ffaŋ] (irrealis negative non-past), *ff-i* [ffi] (imperative attemporal), and *fu-u* [fu:] (realis finitive non-past). For the basic verbal morphology of Irabu Ryukyuan, see also 3.4.

The phonological interpretation of /l/ is somewhat controversial. The problem lies in the fact that /l/ exhibits a split identity, namely, it is vowel-like in some respects and consonant-like in others. For example, /l/ behaves like a vowel in terms of syllable structure, but it behaves like a consonant in terms of morphophonology (*mal* ('rice')-*yu* (accusative case)→*malzu*; *tur* ('bird') -*yu*→*turru*, see 2.3.1 for further reference of this on-glide allomorphy).

#### 2.1.4. Phonotactics

The syllable structures as found in Irabu Ryukyuan can be reduced to the following set of structures, depending on the type of the syllable nucleus.

(C1)(C2)(S)V1(V2)(C3)

(40) *yakkan* [jakkaŋ] 'kettle' (41) *ttam* [ʔtam] 'came' (42) *nkyaan* [ŋkja:ŋ] 'long ago'

(C)C1(C2)

(43) *brbrgassa* [b|b|gassa] 'alocasia odora' (44) *mmna* [m:na] 'all'

(45) *ftai* [ftai] 'front head'

## 2.2. Supersegmental phonology

### 2.2.1. Accent

Accent is not phonemic in Irabu Ryukyuan. However, each word carries a phonetic accent (pitch accent). Some words have their fixed pitch accent patterns, while others are pronounced differently in person to person.

### 2.2.2. Intonation units

As in many other languages, intonation is one of the crucial devices for expressing syntactic boundaries and discourse functions in Irabu Ryukyuan. For example, the suspending form (see 3.4.1) tends to carry a rising intonation, to mark the syntactic boundaries.

(46)   
*dzadzaa=ttii ur-i-i*      *ur=yaa pa-r-tar=tsa.*  
 OMTp=QT      descend-INF-SUS    3SG=TOP    leave-FIN-PAST2=HS

'The tsunami came down with the wave, then she came back to the sea.'

Note here that the syntactic information that *dzadzaa=ttii ur-i-i* is a subordinate clause is marked by the rising intonation, instead of, say, conjunction enclitics.

## 2.3. Morphophonology

### 2.3.1. Typical allomorphy in affixation and cliticization

When an affix whose onset is a vowel or a semivowel (**-V** or **-SV**) attaches to a morpheme whose final phoneme is a consonant (**C**), the affix carries an onset consonant whose place of articulation is the same as the preceding consonant (**C<sub>i</sub>**)-**C<sub>i</sub>V**). This allomorphy does not apply to cliticization or syntactic juxtaposition. That is, this allomorphy does not apply over the word boundary.

(47) <i>a-s-siba</i> [aʃʃiba]	(48) <i>tur-ru</i> [tuʃʃu]	(49) <i>tur=yaiba</i> [tuʃʃaiba]
<i>a-s-iba</i>	<i>tur-yu</i>	<i>tur=yaiba</i>
do-FIN-CONJ	bird-ACC	bird=CONJ
‘then’	‘bird (accusative)’	‘since it is a bird’

### 2.3.2. Typical allomorphy in compounding

The most frequently observed morphophonological alternation concerned with compounding is the voicing alternation, where a voiceless stop/fricative alternates with its voiced counterpart.

/p/→/b/	/k/→/g/	/f/→/v/
(50) <i>satu+bItu</i> [satob <sup>z-0</sup> ʃtu]	(51) <i>maku+gan</i> [makogan]	(52) <i>irav+vtsI</i> [iravutsɿ]
satu+pʃtu	maku +kan	irav+ftsI
‘neighbor’	‘coconut crab’	‘the Irabu language’

In my data, /p/, /t/, /k/, and /f/ may undergo this allomorphy, alternating with /b/, /d/, /g/, and /v/ respectively, while /s/ does not alternate with /z/. This would be due to the fact that /z/ and /s/ show some asymmetry in terms of phonetic characteristic. Namely, /z/ is phonetically very similar to [ʒ] rather than [z], such that /z/ is not really a voiced counterpart of /s/ (see also 2.1.2 for a phonological analysis on /z/).

## 3. Morphology

### 3.1. Major grammatical categories

In this section, I will attempt to categorize independent words of Irabu Ryukyuan into several major grammatical categories.

As will be shown below, it is possible in Irabu Ryukyuan to set the following four major grammatical categories: nouns, verbs, adjectives, and adverbs. The setting of each of the first three categories will be justified on its own distinct set of structural and distributional features. On the other hand, the grammatical category adverb is a catch-all category, which would be labeled “others”. An independent word must be either a noun, a verb, an adjective,

or an adverb. Non-independent forms (affixes and clitics) will be discussed in the section for word formation in 3.2.

### 3.1.1. Nouns

The grammatical category noun in Irabu Ryukyuan has the following typical structural features (see also 3.3 for a detailed description of nominal morphology).

- a) Nouns can be modified by a word carrying the genitive case *-ga/-nu* (see 3.3.2)
- b) Nouns can be suffixed by case markers (see 3.3.2).
- c) Nouns can be cliticized by discourse markers such as *=du* (focus) and *=ya* (topic) (see 3.3.4).
- d) Nouns can have no internal structure (i.e. can be composed of the single root alone).

a) is the distinct characteristic of nouns, while b) is shared by adjectives, c) is shared by verbs, and d) is shared by many adverbs. Related to d), there may be no inflectional morphology involved in nouns of Irabu Ryukyuan (however, see also 3.3.1).

The grammatical category noun has the following typical functional features.

- a') Nouns can serve as subjects and objects.
- b') Nouns can serve as the predicate of a clause (see 3.3.1, 4.3.1).
- c') Nouns can serve as the head of a phrase.

a') is the distinct characteristic of nouns, while b') and c') are shared by verbs and adjectives.

Pronouns, numerals, demonstratives, and question words are described as a sub-type of the grammatical category noun<sup>10</sup>.

It is very easy to identify the word boundary of nouns, since a given noun often has no internal structure, and so directly corresponds to a word.

### 3.1.2. Verbs

The grammatical category verb in Irabu Ryukyuan has the following typical structural features (see also 3.4 for a detailed description of verbal morphology).

- a) Verbs can carry the negative suffix *-n*.
- b) Verbs can carry valence changing suffixes such as causative suffixes *-as/-(a)sImi*, and passive/ potential suffix *-(r)ai*.
- c) Verbs can carry the tense/mode suffixes  $-\emptyset$ , *-r*, *-m*, *-tam*, and *-tar*.

a) is the distinct characteristics of verbs, while b) and c) are shared by adjectives (see 3.5.1).

---

<sup>10</sup> The demonstrative modifier plus genitive case *ku-nu* 'this', *u-nu* 'that', and *ka-nu* 'that' might be better described as single morphemes *kunu*, *unu*, and *kanu*. In such a case, these would form a distinct grammatical category as opposed to noun, in the sense that it only functions to modify nouns, and it does not carry any case marker.

The grammatical category verb has the following typical functional features.

a') Verbs can serve as the predicate of a clause.

b') Verbs can serve as the head of a phrase.

c') Verbs can code events in texts.

a'), b'), and c') are all shared by nouns and adjectives. It is very difficult to isolate one functional feature which is ONLY found in verbs, though the structural feature of verbs are easily identified.

Verbs in Irabu Ryukyuan fall into two sub-types: main verbs and auxiliaries. An auxiliary is a verb which shows the features of b) and c), and lacks c'). Namely, it does show some structural features of a verb but is de-lexicalized (grammaticized).

(53a)	<i>ur=yaa</i>	<i>fa-i-i=du</i>	<i>u-r.</i>	(53b)	<i>ur=yaa</i>	<i>fa-i-i=du</i>	<i>u-tar.</i>
	3SG=TOP	eat-INF-SUS=FOC	PRG-NON.PAST2		3SG=TOP	eat-INF-SUS=FOC	PRG-PAST2
	'(S)he is eating.'				'(S)he was eating.'		

As shown in the above pair of examples, *u-r* takes over the task of inflecting for tense/mode. However, it designates an aspectual concept (progressive activity), and lacks some of the semantic contents which the main verb *u-r* 'exist' would have. For example, while the semantics of the main verb *u-r* ('(animate subjects) exist') must require it to co-occur with animate subjects, the auxiliary *u-r* can co-occur with non-animate subjects as well.

(54)	<i>kabII-nu=du</i>	<i>uti+u-r.</i>	cf.	<i>kabII-nu=du</i>	<i>*u-r/a-r.</i>
	paper-NOM2=FOC	fall+PRG-NON.PAST2		paper-NOM2=FOC	exist-NON.PAST2

'A paper is falling/ there is a paper (on the floor, etc.)' 'there is a paper.'

The border between main verbs and auxiliaries is sometimes ambiguous. For example, *nyaan* as in the following example is like auxiliaries, in that it inflects for tense/mode and is de-lexicalized to some degree (*nyaan* 'not exist' → 'have done (perfect)').

(55)	<i>kar=yaa</i>	<i>pai-nkai</i>	<i>par-i-i</i>	<i>nyaat-tam.</i>	cf.	<i>kabII-nu=du</i>	<i>nyaan.</i>
	3SG=TOP	farm-DAT2	leave-INF-SUS	PERF-PAST1		paper-NOM2=FOC	not.exist
	'(S)he had gone to the farm.'					'I have got no paper.'	

On the other hand, *nyaan* is not like auxiliaries in that while the proto-typical auxiliary *u-r* as noted above can form a compound verb with the stem of the main verb (as in example 54), *nyaan* cannot.

(56)	<i>par-i-i</i>	<i>nyaan.</i>	cf.	<i>*par-i+nyaan.</i>
	leave-INF-SUS	PERF		
	'It has gone.'			

This structural constraint is typical in main verbs. Namely, when two main verbs juxtapose, the first one has to be the suspending form (V1<sub>[sus]</sub> V2, see 3.4.1 for the notion "suspending form"). Thus *nyaan* (perfect) is situated between the proto-typical auxiliaries and the proto-typical main verbs.

### 3.1.3. Adjectives

The grammatical category adjective in Irabu Ryukyuan has the following typical structural features (see also 3.5 for a detailed description of adjectival morphology).

- a) Adjectives can be negated by the negative form *nyaan*.
- b) Adjectives can be a reduplicated form.
- c) Adjectives can carry the suffix *-munu*
- d) Adjectives can carry the genitive case marker *-nu*
- e) Adjectives can carry the past tense marker *-tam/-tar*.

a) and b) are the distinct structural characteristics of adjectives, while c) and d) are shared by nouns and e) is shared by verbs.

The grammatical category adjective has the following typical functional features (see also 3.5.1).

- a') Adjectives can serve as the modifier of nouns.
- b') Adjectives can serve as the predicate.

a') and b') are shared by nouns and verbs.

As is evident, adjective is structurally distinct from nouns and verbs (in terms of a) and b) above). Thus in Irabu Ryukyuan it is a justified description to set the grammatical category adjective. However, it does share some nominal/verbal structural features. As for its functional feature, adjective shows both nominal and verbal features, serving as “nouns” or “verbs”.

### 3.1.4. Adverbs

Adverbs share no structural or distributional features. Included in this “catch-all” category are adverbial words such as *yagami* ‘very’, vocative-like nouns such as *agu(u)* ‘buddy!’, etc. It is sometimes ambiguous whether a given element is an adverb (independent word) or a clitic (phonologically/morphologically dependent word).

## 3.2. Basic word formations

### 3.2.1. Introduction

In this section I will focus on how the basic word formation in Irabu Ryukyuan is carried out.

The basic word formation in Irabu Ryukyuan can be reduced to the following two major types, irrespective of word classes such as noun, verb, and adjective:

**Root plus non-Root**...Affixation and cliticization: Root(-SUFFIX(es))(=ENCLITIC(s))

**Root plus Root**...Reduplication and compounding: Root<sub>1</sub>+Root<sub>2</sub>

In the sections below, I will sketch out 1) what distinguishes between affixes and clitics in Irabu Ryukyuan, 2) what kind of affixes and clitics are to be identified in Irabu Ryukyuan, 3) what kind of reduplication is employed in Irabu Ryukyuan, and 4) what kind of compounding is employed in Irabu Ryukyuan. More detailed nominal/verbal/adjectival word

formations and morphological structures will be described in separate sections later (in 3.3, 3.4, and 3.5).

### 3.2.2. Affixation and cliticization

#### 3.2.2.1. Formal criteria for clitics and affixes

Clitics must attach to an independent word, while affixes may attach to bound forms. Affixes cannot attach to a word carrying clitics, while clitics can (-X=Y, -X=Y=Z but \*=Y-X). Affixes may trigger an accent shift and/or the on-glide allomorphy (see 2.3.1), while clitics do not. Affixes typically attach to one grammatical category (e.g. verb), while clitics may attach to several different categories (e.g. verb and noun).

The topic marker =*ya* is problematic here. =*ya* triggers, or is subject to, many morphophonological alternations, among which is the on-glide allomorphy.

(57) *par=ra* [pa|**ɹ**a]            \**par=ya* [pa|j**a**]

*par=ya*  
 needle=TOP  
 ‘needle (topic)’

In this single respect =*ya* is arguably an affix. However, =*ya* can attach to several different grammatical categories, and it always closes the further affixation/cliticization. Furthermore, it functionally contrasts with the focus marker =*du* or =*ga*. These may indicate that it is adequate to describe =*ya* as a clitic. Thus in this paper I assume that =*ya* is a clitic.

#### 3.2.2.2. List of non-independent forms

Below is a list of major non-independent forms in Irabu Ryukyuan, some of which are discussed in some length in this paper.

Table 2. List of non-independent forms

	Nominal morphology	Verbal morphology
Affix	Case suffix (see 3.3.2) Plural suffix (see 3.3.3) Diminutive (3.3.5) Nominal adjective derivational suffix (see 3.5.1)	Verbal derivational suffix (see 3.4.1) Verbal inflectional suffix (see 3.4.1) Conjunction suffix Verbal adjective derivational suffix (see 3.4.1)
Clitic	Topic/focus markers (see 3.3.4)	Mode enclitics (see 4.6.3) Question enclitics (see 4.6.5) Other discourse enclitics (4.6.6) Conjunction enclitics

### 3.2.3. Reduplication

Reduplication in Irabu Ryukyuan is a crucial morphological process for forming adjectives (see 3.5.1 for a further description of adjectival morphology). The reduplication concerned with adjectives in Irabu Ryukyuan is a full reduplication. Namely, the whole root is reduplicated. Note, however, that the reduplication requires the morpheme-final phoneme of the first root to be lengthened. This distinguishes reduplication and compounding (see 3.2.4 below) in Irabu Ryukyuan.

[ <i>taka-</i> ‘high’]	[ <i>ssu-</i> ‘white’]	[ <i>sabitsI-</i> ‘lonely’]	[ <i>kiban-</i> ‘poor’]
(58) <i>takaa+taka</i>	(59) <i>ssuu+ssu</i>	(60) <i>sabitsII+sabitsI</i>	(61) <i>kibann+kiban</i>
high+high	white+white	lonely+lonely	poor+poor
‘very high’	‘really white’	‘very lonely’	‘very poor’

### 3.2.4. Compounding

Compounding in Irabu Ryukyuan typically concerns compound nouns (Noun+Noun; Noun+Verbal stem; Adjectival root+Noun) and compound verbs (Verbal stem+Verb). However, in a few (probably lexicalized) expressions, compound adjectives (Noun+Adjectival root) are observed, as in example 66.

(62) <i>mi+pana</i>	(63) <i>mm+pur-i</i>	(64) <i>uku+gamatsI</i>	(65) <i>fa-i+u-tam</i>
eye+nose	potato+dig-INF	big+cheek	eat-INF+PRG-PAST1
‘face’	‘potato-digging’	‘angry man’	‘I was eating.’
(66) <i>pIsara+pIguru</i>			
Hirara+cold			
‘cold as Hirara people’			

Compounds are distinguished from phrases on the following formal grounds:

- 1) Compounds may trigger the voicing alternation (see 2.3.2).
- 2) Compounds may trigger the vowel shortening of either element (*mi+pana* ‘face’ as in example 62; cf. *mii* ‘eye’)
- 3) Compounds may trigger the semivowel blending ( $i+(y)e \rightarrow yee/ i+(y)u \rightarrow yuu$ ) on the boundary of the two elements, just as in the case of affixation (*saki-yu* ‘liquor (accusative)’  $\rightarrow$  *sakyuu*).

## 3.3. Basic nominal morphology

### 3.3.1. Introduction

The basic nominal structure of Irabu Ryukyuan is schematically shown below.

[Root]-[Suffix [number/definiteness]]-[Suffix [case]]=(Enclitic [topic/focus])

(67) <i>gakusyee-mmi-nagi-nu=du</i>	<i>ark-i+u-tar.</i>
student-PL1-IND-NOM2=FOC	walk-INF+PRG-PAST2
‘Students or suchlike were walking.’	

Nouns themselves do not inflect for person/number/case, whereas it may carry case markers and/or discourse markers (topic/focus). In terms of frequency, a noun tends to carry some case suffix to function in a sentence as an argument of the predicate. When a given noun does not carry any case markers, it may signal that the noun serves as a predicate by itself (see also 4.3.1).

(68) *ba=a sinsii*  
 1SG=TOP teacher  
 ‘I am a teacher.’

The case suffix is thus inflectional to some degree, in the sense that the syntactic status as a nominal argument requires it (cf. Bybee 1985).

### 3.3.2. Nouns and case markers

Below is the list of case markers as identified in Irabu Ryukyuan.

Table 3. Case suffixes

	Name	Allomorph (s)	Syntactic function (s)
-ga	Nominative 1 Genitive 1	-ga	Subject index/Genitive index/Object index
-nu	Nominative 2 Genitive 2	-nu	Subject index/Genitive index <sub>2</sub>
-yu	Accusative	-yu/ -yuu /-u/ -nuu/ Cu <sup>11</sup>	Object index
-n <sup>12</sup>	Dative 1	-n/ -ø	Object index/Locative index/Subject index
-nkai	Dative 2	-nkai/ -kai	Object index/Locative index
-nkii	Locative	-nkii/-kii	Locative index
-gami	Allative	-gami	Allative index/ emphasis <sup>13</sup>
kara	Ablative	-kara	Ablative index
-sii	Instrumental	-sii	Instrumental index
-tu	Comitative	-tu	Comitative index
-yarruu	Comparative	-yarruu	Comparative index

<sup>11</sup> C: on-glide consonant. See 2.3.1 for further reference.

<sup>12</sup> These days many people replace -n and -nkai with -ni, which may be a borrowing from Japanese dative case suffix -ni. In this study I did not include -ni within the case morphology of Irabu Ryukyuan, though this description would be modified in future researches.

<sup>13</sup> -gami may be used to emphasize the subject which already carries the nominative case suffix.

*vva-ga-gami=du as-I-tar!*  
 2SG-NOM1-ALL=FOC do-FIN-PAST2  
 ‘It is you that did it!’

One of the conspicuous characteristics of the case morphology of Irabu Ryukyuan would be that subject and possessor may be marked with the identical case marker, and that there are two such nominative/genitive case markers (-*ga* and -*nu*).

(69a) *setsIko-ga ffa* (69b) *kai-ga ffa* (69c) *taugagara-nu ffa* (69d) *kunu in-nu ffa*  
 Setsuko=GEN1 child 3SG-GEN1 child someone-GEN2 child this dog-GEN2 child  
 ‘Setsuko’s child’ ‘His/Her child’ ‘someone’s child’ ‘This dog’s puppy’

(70a) *setsIko-ga=du ffa-u nas-I-tar.*  
 Setsuko-NOM1=FOC child-ACC bear-FIN-PAST2  
 ‘Setsuko gave birth to a baby.’

(70b) *kai-ga=du ffa-u nas-I-tar.*  
 3SG-NOM1=FOC child-ACC bear-FIN-PAST2  
 ‘She gave birth to a baby.’

(70c) *kunu in-nu=du ffa-u nas-I-tar.*  
 This dog-NOM2=FOC child-ACC bear-FIN-PAST2  
 ‘This dog gave birth to a baby.’

Though still unclear at this stage, the condition of which case marker is selected between -*ga* and -*nu* seems to correlate crucially with a set of mutually related notions of identifiability (definiteness), animacy, and topicality. The higher value these three variables show, the more probable it is to select -*ga* rather than -*nu*. This applies equally to the genitive -*ga*/-*nu* and the nominative -*ga*/-*nu*, as is evident in the above examples<sup>14</sup>. It seems then that this condition is in association with the so-called “topic-worthiness hierarchy” (cf. Payne 1997; see also Silverstein 1976). This hypothesis must be further elaborated in future researches based on context-oriented, i.e. text-based analyses.

### 3.3.3. Plurality

Irabu Ryukyuan does not have a grammaticized (obligatory) number distinction, but have optional plural suffixes -*mmi* and -*ta*. They are only used for marking the plurality of animate referents.

(71) *ffa-mmi* (72) *uya-mmi* (73) *tur-mmi* (74) *dyundzi-ta* \**kabII-mmi/-ta*  
 child-PL1 father-PL1 bird-PL1 Junji-PL2 paper-PL1/-PL2  
 ‘children’ ‘parents’ ‘birds’ ‘Junji and his company’ ‘papers’

In terms of frequency in texts, -*ta* is more likely to mark “*et al*” plurality (as opposed to a “genuine” plurality) than is -*mmi*. In example 74 above, for example, *dyundzi-ta* means that there are Junji (person name) and his company, and not that there are several Junji’s. -*ta* tends to co-occur with person names and kinship terms such as *uya* ‘father’ and *annna*

<sup>14</sup> Therefore it might be adequate not to distinguish the genitive -*ga*/-*nu* and nominative -*ga*/-*nu*, though this paper tentatively assumes that these two are different sets of morphemes.

‘mother’.

### 3.3.4. Topic/Focus marking

The topic is marked by =*ya* and =*ba(a)*, while the sentential focus is marked by =*du* (in declarative sentences), or =*ga* (in question sentences).

(75) *tsInoo=ya kar=yaa pIsara-nkai=du pa-r-tar.*  
 yesterday=TOP 3SG=TOP Hirara-DAT2=FOC leave-FIN-PAST2

‘Yesterday (s)he went to Hirara.’

The topic marker =*ya* replaces the nominative/genitive case suffixes *-ga* and *-nu* and the accusative case suffix *-yu*, but does not replace other case suffixes such as the locative suffix *-nkii*. In such a case =*ya* just attaches to the case suffix (*-nkii=ya*). It is therefore argued that =*ya* replaces the case suffix of the core arguments (see also 4.4.4). Another topic marker =*ba(a)* only attaches to the accusative case suffix *-yu*. The focus markers =*du*/*=ga* attaches to any of the case suffixes.

### 3.3.5. Diminutives

The diminutive suffix *-gama* is quite frequently observed in texts and in elicitations, and its productivity (i.e. the ability to attach to roots and derive word forms) is high, though its main host is noun. For example, *-gama* is to be used as in *ffa-gama* ‘child’ (nominal root plus *-gama*), and *uyaki-gama* ‘rich’ (adjectival root plus *-gama*).

### 3.3.6. Pronouns

Below I will present the basic pronominal system in Irabu Ryukyuan.

Table 4. Pronominal set in Irabu Ryukyuan

	Singular	Plural
1 <sup>st</sup> person	<i>ban/ ba-</i>	<i>banti/ bant-</i>
2 <sup>nd</sup> person	<i>vva</i>	<i>vvadu</i>
3 <sup>rd</sup> person	<i>ku(r)i/ u(r)i/ ka(r)i</i>	<i>kunukya/ unukya/ kanukya</i>

The third person pronouns are demonstrative pronouns. The third person referent is encoded differently depending on its locational/ contextual grounding.

There is a lexeme *duu* ‘we (you and me)’ which is analogous to the so-called “first person inclusive” pronoun. However, its genitive form is *duu-nu*, while those of all the other pronouns in the table are *ba-ga*, *vva-ga*, *kui-ga*, *banti-ga*, *vvadu-ga*, *kunukya-ga*, etc., requiring the genitive suffix *-ga* rather than *-nu*. Based on this, I do not include *duu* in the pronominal set of Irabu Ryukyuan.

### 3.4. Basic verbal morphology

In this section, I will describe the basic verbal morphology in Irabu Ryukyuan, with a special focus on two major types of verbal structures. Henceforth I will refer to these two as TYPE 1 and TYPE 2 respectively.

#### 3.4.1. TYPE 1

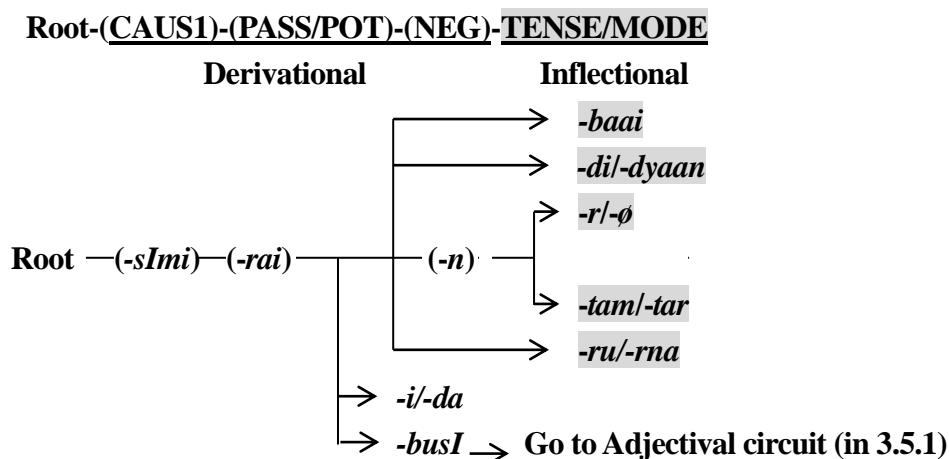

Figure 3. Basic verbal morphology (1): TYPE 1 (TYPE 1 circuit)

The causative suffix *-sImi* (CAUS 1), the passive/ potential suffix *-rai* (PASS/POT), the suspending form derivational suffix *-i/-da*, the adjectival stem derivational suffix *-busI*, and the negative suffix *-n*<sup>15</sup> (NEG) are optional in the verbal morphology (i.e. derivational), while the tense/mode markers (TENSE/MODE) such as *-baai* (optative attemporal), *-di/-dyaan* (intentional attemporal), *-r/-∅* (indicative non-past), *-tam/-tar* (indicative past), and *-ru/-rna* (imperative attemporal) are obligatory to produce an independent verb word which may end the sentence (i.e. inflectional). The inflected forms may appear in main clauses, relative clauses, and other several subordinate clauses. However, none of them can appear, for instance, in the conditional clause.

The optative suffix *-baai* corresponds to ‘I want to...’. *-baai* only co-occurs with the first person subject, and does not have tense distinction.

- |                      |                           |                          |
|----------------------|---------------------------|--------------------------|
| (76) <i>mii-baai</i> | (77) <i>mii-sImi-baai</i> | (78) <i>mii-rai-baai</i> |
| look-OPT             | look-CAUS1-OPT            | look-PASS-OPT            |

‘(I) want to see’    ‘(I) want to make see’    ‘(I) want to be seen’

The intentional attemporal suffixes are *-di* (affirmative) and *-dyaan* (negative). The indicative non-past suffixes *-r* and *-∅* are conditioned by the presence or absence of the negative marker *-n*.

<sup>15</sup> The negative suffix *-n* has allomorphs *-n* and *-t*, the latter being realized when *-n* is followed by the past tense suffix *-tam/-tar* as in *mii-t-tam* ‘did not see’. This morphophonological assimilation (*n*→*t*) is also found in the negative word *nyaan*.

- |                    |                       |                   |  |
|--------------------|-----------------------|-------------------|--|
| (79) <i>mii-di</i> | (80) <i>mii-dyaan</i> | (81) <i>mii-r</i> | (82) <i>mii-n-<math>\emptyset</math></i> |
| look-INT           | look-INT.N            | look-NON.PAST     | look-NEG-NON.PAST                        |
| ‘(I) will look’    | ‘(I) will not look’   | ‘(I) look’        | ‘(I) do/will not look’                   |

*-tam/-tar* is the past tense suffix. See 4.6.1 for further references of tense marking.

*-ru/-rna* is the imperative suffix. *-ru* is the affirmative, and *-rna* is the negative form.

The root may be followed by a derivational suffix *-i* (affirmative) or *-da* (negative). The resulting form will be labeled *suspending form*, which typologically shares some features with the so-called “con-verbs” in other languages. This verbal form functions 1) to extract a verbal stem from the compound verb and convert it into a nominal element to put it in focus, and 2) to suspend the first sentence to make it function as the subordinate clause of the following new clause. The suspending form cannot inflect for tense/mood.

*-busI* is another optative suffix than *-baai*, but it is very different from *-baai* in terms of morphosyntax: while *-baai* is an inflectional suffix to form a finite verb, *-busI* is a derivational suffix to form an *adjective* from the verbal root. That is, *-busI* derives an adjectival stem, which then follows the morphology of adjective (see 3.5.1).

The root of a TYPE 1 verb can form a compound verb with an auxiliary, can form a compound noun with a noun, and may function as an equivalent of the suspending form.

### 3.4.2. TYPE 2

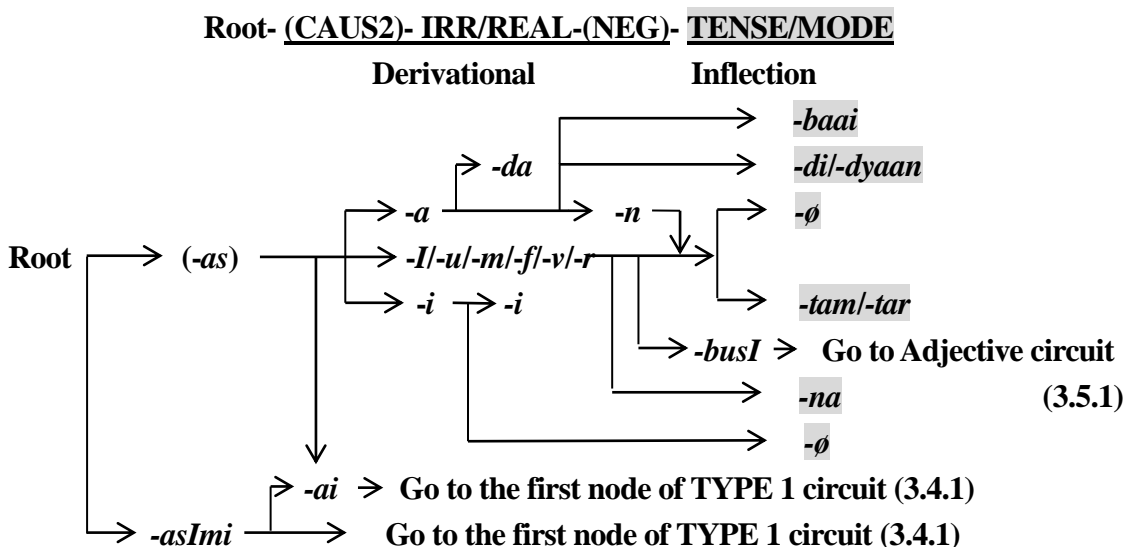

Figure 4. Basic verbal morphology (2): TYPE 2 (TYPE 2 circuit)

The most conspicuous feature of TYPE 2 would be that there are two ways of derivational processes. For example, the root can carry two different causative markers (CAUS 2 *-as* and CAUS 1 *-asImi*), and CAUS 1 follows the derivational/inflectional process of TYPE 1. The passive/ potential marker (PASS/POT *-ai*) also follows the derivational process of TYPE 1. The derivational/inflectional process concerned with CAUS 1 and

PASS/POT is exactly the same as the process following the first node of TYPE 1 circuit. In other words, a given TYPE 2 root may be converted into TYPE 1 stem.

**TYPE 1 stem**

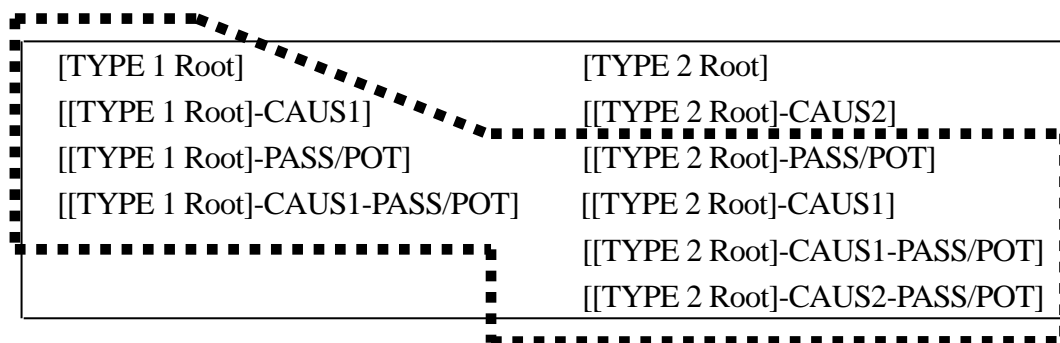

Figure 5. TYPE 2 root and its derivational stems

Note here that a TYPE 2 root may derive not only TYPE 2 stems but TYPE 1 stems as well.

Another feature of interest is that TYPE 2 may mark an irrealis/ realis distinction by way of the (secondary) stem derivational suffix *-a* (the irrealis stem derivational suffix), *-I/-u/-f/-v/-r* (the realis finitive stem derivational suffix), and *-i* (the realis infinitive stem derivational suffix). For example, the following examples are all concerned with irrealis events<sup>16</sup>, and they all contain *-a*.

- |                        |                      |                      |                              |
|------------------------|----------------------|----------------------|------------------------------|
| (83) <i>kak-a-baai</i> | (84) <i>kak-a-di</i> | (85) <i>kak-a-ba</i> | (86) <i>kak-a-n-ϕ</i>        |
| write-IRR-OPT          | write-IRR-INT        | write-IRR-COND       | write-IRR-NEG-NON.PAST       |
| ‘(I) want to write.’   | ‘(I) will write.’    | ‘If (I) write...’    | ‘(I) do not/will not write.’ |

These stem derivational suffixes must attach to the root (or the primary stem, i.e. the root with the CAUS 2 suffix *-as*) to bear the secondary stem which can carry grammatical endings (i.e. derivational/inflectional suffixes). Namely, the secondary stem of TYPE 2 is equivalent to the root of TYPE 1, which is already a “well-oiled” stem which can carry grammatical endings.

- [[TYPE 2 Root]-IRR/REAL]-(NEG)-TENSE/MODE
- [[[TYPE 2 Root]-CAUS2]-IRR/REAL]-(NEG)-TENSE/MODE
- [TYPE 1 Root]-(NEG)-TENSE/MODE

Figure 6. TYPE 2 stem and TYPE 1 stem (Secondary stems are underlined)

The imperative attemporal suffix *-ϕ* attaches to the realis infinitive stem, while its negative form *-na* attaches to the realis finitive stem.

<sup>16</sup> Payne (1997: 244) defines the concept realis/ irrealis as follows: the proto-typical realis mode strongly asserts that a specific event actually happened, or holds true, while the proto-typical irrealis mode makes no such claim whatsoever. That is, an event coded with the irrealis mode does not necessarily mean the situation that did not happen or will not happen. It may happen or may even have happened. This is the case in Irabu Ryukyuan because the irrealis stem derivational suffix *-a* can mark the future intention as well as the negation.

### 3.5. Basic adjectival morphology

#### 3.5.1. Adjectival morphology of the three types of word form

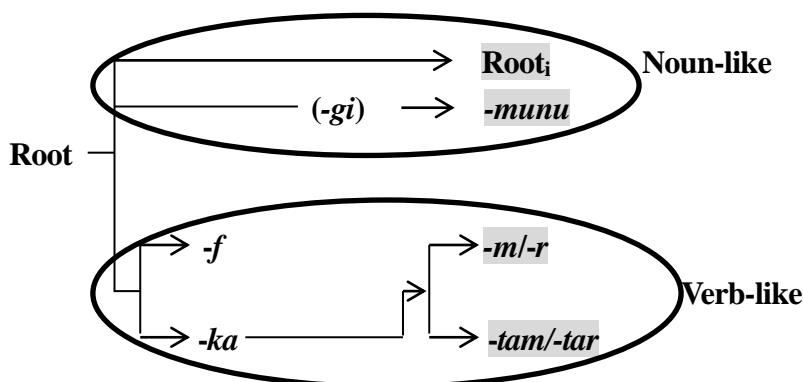

Figure 7. Basic adjectival morphology (Adjective circuit)

Following the above figure, the concept ‘to be delicious’ is coded in the following ways, with the root *mma-* :

- |                      |                      |                        |                  |                        |
|----------------------|----------------------|------------------------|------------------|------------------------|
| (87) <i>mmaa+mma</i> | (88) <i>mma-munu</i> | (89) <i>mma-f=fa</i>   | <i>nyaat-tam</i> | (90) <i>mma-ka-tam</i> |
| delicious+delicious  | delicious-NA         | delicious-ASUS=TOP     | ANEG.-PAST1      | delicious-VA-PAST1     |
| ‘delicious’          | ‘delicious’          | ‘it was not delicious’ |                  | ‘it was delicious’     |

The first two word forms are noun-like, in that they can carry the genitive case suffix *-nu* and can serve as the predicate with the copulative auxiliary verb *a-r/a-m* (non past) or *a-tar/a-tam* (past), as the following examples illustrate.

- (91a) *mmaa+mma-nu*    *fa-u+munu=du*    *a-tar*.  
 delicious+delicious-GEN2    eat-FIN+thing=FOC    COP-PAST2

‘It was a delicious food.’

- (91b) *ur=yaa*    *mma-munu=du*    *a-tar*.  
 that=TOP    delicious-NA=FOC    COP-PAST2

‘It was delicious.’

On the other hand, the examples 89 and 90 are verb-like, since, as will be shown later, *mma-f* in 89 function as the equivalent of the suspending form (see also 3.4.1), and *mma-ka-tam* in 90 carries the tense/mode suffix *-tam*. Hereafter, I will term the noun-like adjectives as in 87 and 88 as **nominal adjectives**, and the verb-like adjectives as in 89 and 90 as **verbal adjectives**.

*-gi* ‘looks like/appears to be’ is a derivational affix which functions to mark a lower evidentiality for the concept that the root expresses (*pisi-munu* ‘be cold (I feel cold)’ vs. *pisi-gi-munu* ‘looks like cold’). This morpheme is obligatory when the adjective concerns the emotional/physical epistemology of the non-first person referents.

- (92) *kar=yaa*    *pisi-gi-munu*    *i*.                      \**kar=yaa*    *pisi-munu*    *i*.  
 3SG=TOP    cold-LE-NA    DSC

‘He appears to feel cold, eh?’

*-f* is a derivational affix which changes the adjectival root into a form which is an equivalent to the suspending form of verbs (see 3.4.1), to be framed into a verb phrase such as *Root-f=du Verb*, as the following example illustrates.

- (93) *mma-f=du*                      *na-r*  
 delicious-ASUS=FOC      become-NON.PAST2  
 ‘It becomes delicious.’

The root plus *-f* is obligatory to be followed by the adjective negative marker *nyaan*, as in *mma-f=fa nyaan* (delicious-ASUS=TOP ANEG) ‘not delicious’. *nyaan* is a grammaticized element of a lexical verb *nyaan* ‘not exist’. Thus the negation in adjectives is made by the analytic structure [Root-ASUS](=TOP) [ANEG].

### 3.5.2. Inflection in Adjectives

As presented in Figure 7, either the reduplicated root, *-munu*, *-m/-r*, or *-tar/-tam*, must be selected to be a full adjective word, and each of them can close the word formation. In this sense, these suffixes are inflectional in the adjectival morphology of Irabu Ryukyuan. Thus in the following pair of example, 94a is a noun phrase with an adjective *word* modifier and a head noun, while 94b is a compound noun, with an adjectival *root* modifier and a head noun (i.e. nominal root).

- (94a) *takaa+taka-nu*    *pItu*                      (94b) *taka+pItu*  
 tall+tall-GEN2      man                                      tall+man  
 ‘a tall man’                                      ‘a tall man’

## 4. Syntax

### 4.1. Word order

In Irabu Ryukyuan, there is a strong constraint that the verb (or the nominal/adjectival predicate) comes sentence-finally. The unmarked word order appears to be (S)(O)V. However, OSV is also found relatively frequently. In the latter case, O tends to be marked for topic with *=ya* or *=baa* (see 3.3.4). The overt marking of S and O is restricted by discourse conditions.

### 4.2. Head/Dependent-marking

Irabu Ryukyuan employs Dependent-marking (cf. Nichols 1986) for marking such relations as possessive relations, argument relations, and clause linkage.

### 4.3. Nominal and verbal predications

#### 4.3.1. Nominal predicates

The nominal predication in Irabu Ryukyuan differs depending on tense and affirmative/negative sentence type. In the past tense (affirmative/negative) and the non-past

tense (negative), a copulative auxiliary is required to support the predicate noun. In the non-past tense (affirmative), the predicate noun can stand alone without the auxiliary.

- (95a) *ba=a sinsii=du a-tar.* (95b) *ba=a sinsii=ya ar-a-n-ø.*  
 1SG=TOP teacher=FOC COP-PAST2 1SG=TOP teacher=TOP COP-IRR-NEG-NON.PAST  
 ‘I was a teacher.’ ‘I am not a teacher.’
- (95c) *ba=a sinsii.*  
 1SG=TOP teacher  
 ‘I am a teacher.’

### 4.3.2. Verbal predicates

Verbal predicates in Irabu Ryukyuan are schematically shown as follows.

Table 5. Verbal predicates

Component	Single verb (incl. Compound verb)	Two (or three) verbs
Main verb	V(=QUE/DSC)	V1 <sub>[SUS]</sub> V2(=QUE/DSC)
Main verb plus auxiliary	V1Root+AUX(=QUE/DSC)	V1 <sub>[SUS]</sub> AUX(=QUE/DSC)

As in the above schema, question suffixes/enclitics (QUE) and/or other discourse-oriented enclitics/words (DSC) may follow the verb word or the auxiliary (AUX). This chunk of verb, auxiliary, and other enclitics/words forms a verbal predicate complex.

## 4.4. Subject and Object

### 4.4.1. Characterization of Subject

The proto-typical subject (definite human agent) can be characterized as exhibiting the following set of morphosyntactic features.

- 1) The proto-typical subject triggers co-reference with the honorific suffix *-(r)ai*.
- 2) The proto-typical subject is co-referential with the reflexive *unagaduu*.
- 3) The proto-typical subject may trigger the so-called “quantifier floating”.
- 4) The proto-typical subject is marked by the nominative case suffix *-ga*

Less proto-typical subjects can be described as lacking some of the above characteristics.

### 4.4.2. Characterization of Direct Object

The proto-typical direct object (definite patient) can be characterized as exhibiting the following set of morphosyntactic features.

- 1’) The proto-typical object can become the subject of the passive sentence.
- 2’) The proto-typical object is marked by the accusative case *-yu*
- 3’) The proto-typical object can be marked by the topic marker *=baa*

Less proto-typical objects lack some of the above characteristics.

#### 4.4.3. Notion of “Indirect Object”

The proto-typical “indirect object” (definite human recipient) could be characterized as exhibiting the following set of morphosyntactic features.

1”) The proto-typical indirect object can become the subject of the passive sentence.

2”) The proto-typical indirect object is marked by the dative case *-n/-nkai*

Whether the grammatical relation “indirect object” is to be set in Irabu Ryukyuan is open to debate, however. For it would be quite sensible to assume that “indirect object” is the direct object which satisfies 1’) above, but lacks 2’) and 3’). Namely, the “indirect object” would be a less proto-typical direct object, in the sense that it carries the semantic role recipient rather than patient, and such a less-prototypical identity is formally marked by the lack of 2’) and 3’). In this paper I assume that the notion “indirect object” is not necessary in the grammar of Irabu Ryukyuan, but subsumed under the grammatical relation direct object.

#### 4.4.4. Core and Periphery

As noted in 3.3.4, the topic marker *=ya* replaces the nominative/genitive case suffix *-ga/-nu* and the accusative case suffix *-yu*, while it does not replace other case suffixes.

Given that the proto-typical subject and object are marked by the nominative and accusative case suffixes respectively (see 4.4.1, 4.4.2), it is possible to describe that in Irabu Ryukyuan the core arguments are sensitive to the topic marking, resulting in the replacement of their case suffixes with the topic marker *=ya*. The periphery arguments, on the other hand, are less sensitive to the topic marking, with their case suffixes maintained when marked by *=ya*. Thus in Irabu Ryukyuan there is at least one morphosyntactic basis for distinguishing the core and periphery arguments.

### 4.5. Valence adjusting operations

#### 4.5.1. Valence decreasing operation: Passive

In Irabu Ryukyuan there are three major morphosyntactic operations to decrease the valence of the predicate, i.e. passive, reflexive, and reciprocal. Among these I will overview the passive operation, where the agent (or Actor which subsumes cognitively agent-like semantic roles, see Foley and Van Valin 1984) is demoted to a peripheral argument and the patient (or Undergoer) appears as subject.

[Active voice]

(96a) *pItu-kiu-nu*      *pItu-nu*      *katabata-u=baa*    *yak-i-i*      *fa-i*,  
 one-CLF-GEN2    man-NOM2    half-ACC=TOP    burn-INF-SUS    eat-INF

‘A man from either house (Actor) burned and ate the half body (Undergoer),’

[Passive voice]

(96b) *katabata fa-ai-i*,

half eat-PASS-SUS

‘My half body (Undergoer) has been eaten...’

The above pair of examples is from the same narrative text. Example 96a is the active sentence from which the passive sentence 96b is derived. Note here that in example 96b, the passive suffix *-ai* appears on the verb, the Actor *pltu-kiu-nu pltu* ‘a man from either house’ is left unstated, and the Undergoer *katabata* ‘half body’ is promoted to the subject.

#### 4.5.2. Valence increasing operation: Causative

The causative operation in Irabu Ryukyuan (here I will focus on *morphological causative*) involves *-(a)sImi* and *-as*. TYPE 1 verbs can only carry *-sImi*, while TYPE 2 verbs can carry *-asImi* and *-as* (see 3.4.1, 3.4.2). It is still unclear at this stage of description whether there is some difference in function, meaning, and frequency between *-as* and *-asImi* in TYPE 2 verbs.

(97) *vva-ga=du kari-u=baa sIn-as-I-tar=duui.*  
 2SG-NOM1=FOC 3SG-ACC=TOP die-CAUS2-FIN-PAST2=DSC

‘You killed him.’

(98) *ba=a kai-n=du sIgut-u yar-asImi-tar.*  
 1SG=TOP 3SG-DAT1=FOC job-ACC do-CAUS1-PAST2

‘I let him do the job.’

There seems to be no restriction on the causative marking of transitive verbs, namely, the same set of causative markers (*-as* and *-(a)sImi*) are equally attached to intransitive and transitive verbs. However, there might be some constraint or tendency associated with the intransitive/ transitive verbal type and causative operation. This will be further clarified by a text-based study, which is one of the future research topics of Irabu Ryukyuan.

## 4.6. TAM, negation, and other predicative operations

### 4.6.1. Tense

The tense distinction in Irabu Ryukyuan is a two-way distinction between past and non-past. The non-past form does not simply designate the non-past tense, but may imply the habitual aspect as well, as will be discussed in 4.6.2. In this sense the tense marking in Irabu Ryukyuan is in strong association with aspect. Also, the tense marking is only found in the indicative mode, so that it is again in association with mode.

Table 6. Tense marking system

	NON-PAST	PAST
TYPE 1 affirmative	<i>-r</i>	<i>-tam/-tar</i>
TYPE 2 affirmative	$-\emptyset$	<i>-tam/-tar</i>
Auxiliary affirmative	<i>-m/-r</i>	<i>-tam/-tar</i>
Verbal adjective affirmative	<i>-m/-r</i>	<i>-tam/-tar</i>
Negative of all types	$-\emptyset$	<i>-tam/-tar</i>

In the above table it is clear that the past tense suffix of all the types and the non-past tense suffixes of auxiliary (affirmative) and verbal adjective (affirmative) consist of two forms, seemingly contrasting in *m* component and *r* component. According to the text data, the following tendencies can be gained concerning the condition on the selection between these two forms.

#### [Evidentiality]

If the action or the state encoded by the predicate is highly evidential, tense may be selected between the *-m* form and the *-r* form; otherwise, tense tends to be encoded by the *-r* form.

(99a) *ur=yaa gakkoo-nkai pa-r-tam.* (99b) *ur=yaa gakkoo-nkai=du pa-r-tar.*  
 3SG=TOP school-DAT2 leave-FIN-PAST1 3SG=TOP school-DAT2=FOC leave-FIN-PAST2

‘He went to school (I saw it/I am sure he did)’

(99c) *ur=yaa gakkoo-nkai pa-r-tar=tsa.* (99d) *ur=yaa gakkoo-nkai=du pa-r-tar=tsa.*  
 3SG=TOP school-DAT2 leave-FIN-PAST2 3SG=TOP school-DAT2=FOC leave-FIN-PAST2=HS

‘He went to school, I heard.’

In example 99c and 99d, the “hearsay” enclitic =*tsa* appears since the event encoded is not a first-hand information. In my text data, there was no example where =*tsa* and *-tam* co-occur.

#### [Focus]

If the tense form can be selected between the *-m* form and the *-r* form, it tends to be selected depending on the information status of the predicate. Namely, if the predicate is in focus (i.e. new information), the *-m* form tends to be used, and if the predicate is not in focus (i.e. old information, instead one of the arguments is put in focus with the focus marker =*du*=*ga*), the *-r* form tends to be used.

**-m: Focused non-past**

**-tam: Focused past**

**-r: Presupposed non-past**

**-tar: Presupposed past**

(100a) *ar-f-tam.*

walk-FIN-PAST1

‘I walked’

(100b) *sawada-gami=du \*ar-f-tam/ar-f-tar*

Sawada-ALL=FOC

walk-FIN-PAST1/walk-FIN-PAST2

‘I walked to Sawada’

(101a) *vva=a ar-f-tam-mu?*  
 2SG=TOP walk-FIN-PAST-QUE

‘Did you walk?’

(101b) *taru-nu=ga ar-f-tar?*  
 who-NOM2=FOC walk-FIN-PAST2

‘Who walked?’

There is much more to be done before concluding the exact function of the *-m* form and the *-r* form<sup>17</sup>, based on a sound analysis with extensive text data.

#### 4.6.2. Aspect

In Irabu Ryukyuan, aspect can be encoded either by way of grammaticized forms or of other optional operators. A grammaticized aspect is the progressive aspect. Namely, this aspect cannot be encoded without using the following constructions.

**V<sub>[sus]</sub>=FOC *u-r/u-tar***

**V Root+*u-r/u-tar***

In the above schema, the sentence-final *u-r/u-tar* are the progressive auxiliaries. The main verb and the auxiliary may be syntactically juxtaposed (with the main verb being the suspending form) or morphologically compounded (thus more accurately resulting in a single verb) depending on whether the main verb is in focus.

(103a) *ba-ga ffa-nu ba-nuu mii-i=du u-r.*  
 1SG-GEN1 child-NOM2 1SG-ACC look-SUS=FOC PRG-NON.PAST2

‘My child is looking at me.’

(103b) *ba-ga ffa-nu =du mii+u-r.*  
 1SG-GEN1 child-NOM2=FOC look+PRG-NON.PAST2

‘My child is looking (at something).’

This construction encodes the progressive aspect if the main verb is an action atelic verb (e.g. *miir* ‘look’), while it encodes the *current state* if the main verb is an action telic verb (e.g. *sIn* ‘die’).

As for other aspects, the simple indicative form can imply many of them. For example, the perfective aspect (i.e. an action as its entirety, see Comrie 1978) is typically encoded with the indicative past/non-past form. For the habitual aspect, it is again possible to get away with the indicative form, or the adverb *mainitsI* ‘everyday’, etc., is optionally added to support the semantics of the perfective aspect.

For the perfect aspect (i.e. an action which has been completed at the current moment; NOT the perfective aspect as above), it is possible to use the indicative past form,

<sup>17</sup> It could also be possible to isolate the *m* component and the *r* component as two different morphemes which are independent of tense, designating the information status of the predicate to which it is attached. Namely, *-tam/ -tar* could be further analyzed as *-ta-m/ -ta-r*.

or to use the following constructions, which are very similar to the constructions of the progressive aspect.

**TYPE 1: Root-(CAUS1)-(PASS/POT)-SUS *nyaan***

**TYPE 2: Root-(CAUS2)-INF-SUS *nyaan***

In the above schema, the sentence-final *nyaan* is the perfect auxiliary, which is grammaticized from the main verb *nyaan* ‘not exist’. The main verb root and the auxiliary cannot be compounded, unlike the progressive construction.

(104) *in-nu=du par-i-i nyaan.*  
 dog-NOM2=FOC go-INF-SUS PERF

‘The dog has gone.’

This construction of the perfect aspect is not a grammaticized construction since it can be replaced by the indicative form. Also noted is that this construction tends to be restricted to the action whose effect is visible (*?mii-i nyaan* ‘has watched (the movie, etc.)’)<sup>18</sup>.

#### 4.6.3. Mode

As in many languages, mode crucially correlates with tense in Irabu Ryukyuan. Namely, in Irabu Ryukyuan, tense distinction is only found in the indicative mode.

Below I will show the mode system which is integrated into the verbal inflectional morphology (see also 3.4.1 and 3.4.2), using the verbal root *mii*- ‘look’.

Table 7. Mode system

	Affirmative	Negative
Optative (attemporal) <sup>19</sup> ‘want to’	<i>mii-baai</i>	
Intentional (attemporal) ‘I will’	<i>mii-di</i>	<i>mii-dyaan</i>
Indicative (non-past/past) ‘do/did’	<i>mii-r/mii-tam mii-tar</i>	<i>mii-n-ø/mii-t-tam mii-t-tar</i>
Imperative (attemporal) ‘You do’	<i>mii-ru</i>	<i>mii-rna</i>

As noted in 3.4.2, TYPE 2 verbs must exhibit irrealis/realis modal distinction by carrying the stem derivational suffix.

#### 4.6.4. Negation

Negation is made by using two distinct negative markers *-n* (for verbs) or *nyaan* (for adjectives).

(105a) *nara-n=na kuu-rai-n-ø=ti, aI-tar=tsa.*  
 1SG-DAT1=TOP come-POT-NEG-NON.PAST=QT say-PAST2=HS

‘(She) said “so I can’t come back to you”.’

<sup>18</sup> This observation is based on the actual occurrences in texts. In elicitation, on the other hand, some consultants judged *mii-i nyaan* ‘has watched’ as acceptable.

<sup>19</sup> I could not elicit or collect the natural data of the negative form of *-baai*. To express the equivalent message, *mii-busI-f=fa nyaan* ‘don’t want to see’ is used (see 3.4.1, *-busI*).

- (105b) *kur=yaa dzau-f=fa nyaat-tam=duui.*  
 3SG=TOP good-ASUS=TOP ANEG-PAST1=DSC  
 ‘This was not so good.’

#### 4.6.5. Questions

There are two major morphosyntactic operations to encode questions in Irabu Ryukyuan. One is concerned with yes-no questions, and the other is with content questions (so-called “Wh-questions”).

[Yes-no questions: *-u* (verbal predicates)/=*ru* (nominal predicates)]

- (106a) *kaf-tam-mu?* (106b) *vva=a gakusyee=ru.*  
 write-PAST1-QUE 2SG=TOP student=QUE  
 ‘Have you written?’ ‘Are you a student?’

[Content questions: =*ga*]

- (107) *ndza-n=ga ffa-u nasi+a-r=ga?*  
 where-DAT1=FOC child-ACC bear+RSL-NON.PAST2=QUE  
 ‘Where has she delivered a baby?’

Though the question suffixes/enclitics are not obligatory to encode questions, yes-no questions are more likely to be marked with the question suffix *-u/=ru* than content questions are with =*ga*.

#### 4.6.6. Other discourse markers

In texts, there are a wide range of words and clitics which encode modal and/or other discourse-oriented functions. Structurally these discourse markers appear at the end of the sentence, to “close-off” the predicate complex (see 4.3.2). Shown below are some of those discourse markers as identified in Irabu Ryukyuan.

- =*tsa* [hearsay evidence]  
 =*duui* [emphasis]  
 =*m* [emphasis]  
 =*padzI* [guess]

Detailed analyses on these forms based on an extensive text data will enable us to further clarify the exact functions of these discourse markers.

### 5. Sample text: *The tragedy of mamakudai*

Below is a sample text which would help readers pick up on what Irabu Ryukyuan is like. This text is one of many old stories and legends involving *tooriike*, which is situated on Shimoji Island next to Irabu Island (see Map 3)<sup>20</sup>. The text was narrated by a 92 year-old female native speaker of Irabu Ryukyuan (Sawada-Nagahama dialect), and was recorded and transcribed by the present author.

<i>umandu,</i>	<i>mamakudaiti</i>	<i>mata</i>	<i>artiibadu</i>	<i>i</i>
uma-n=du	mamakudai=ti	mata	ar=tii=ba=du	i
there-DAT1=FOC	mamakodai=QT	and	exist=QT=TOP=FOC	DSC

‘There is a place which is called *mamakodai* over there, eh?’

<i>mamakudaitii</i>	<i>asI tukuman</i>	<i>naugara</i>
mamakudai=tii	asI tukuma-n	naugara
mamakodai=QT	do place-DAT1	well

‘To the place which we call *mamakodai*, well, ’

<i>mamaannaga</i>	<i>mamaffatu</i>	<i>naaga</i>	<i>ffatu</i>	<i>saariikii</i>
mama-anna-ga	mama-ffa-tu	naa-ga	ffa-tu	saar-i+ik-i-i
in.low-mother-NOM1	in.low-child-COM	true-GEN1	child-COM	accompany-INF+go-INF-SUS

‘a stepmother took her stepchild and true child,’

<i>imnu</i>	<i>munu</i>	<i>turtii</i>	<i>saariikii</i>
im-nu	munu	tu-r-∅=tii	saar-i+ik-i-i
sea-GEN2	thing	take-FIN-NON.PAST=QT	accompany-INF+go-INF-SUS

‘saying “let’s go and gather some sea stuff” ’

<i>mamaffauba</i>	<i>utsIni</i>	<i>nivvasI</i>
mama-ffa-u=baa	utsI-ni	niv-vas-I-∅
in.low-child-ACC=TOP	inside-DAT1	sleep-CAUS2-FIN-NON.PAST

‘and she let her stepchild sleep at her side, ’

<i>naaga</i>	<i>ffauba</i>	<i>utsIni</i>	<i>nivvasI</i>
naa-ga	ffa-u=baa	utsI-ni	niv-vas-I-∅
true-GEN1	child-ACC=TOP	inside-DAT1	sleep-CAUS2-FIN-NON.PAST

<sup>20</sup> *Tooriike* is literally a “trans-pond” where there are two unique pair of ponds, connecting to each other in the deep bottom, and they connect to the sea as well.

‘no, she let her true child sleep at her side,’

*mamaffaubaa*      *pukani*      *nivvasii*  
 mama-ffa-u=baa      puka-ni      niv-vas-i-i  
 in.low-child-ACC=TOP      outer.side-DAT1      sleep-CAUS2-INF-SUS

‘while she let her stepchild sleep at the outer side,’

*mapadaatinu*      *tukuman*      *nivvasii*      *utaryaa*  
 mapadaa=ti-nu      tukuma-n      niv-vas-i-i      u-tar=yaa  
 rocky=QT-GEN2      place-DAT1      sleep-CAUS2-INF-SUS      PRG-PAST2=TOP

‘and they were sleeping on a rocky, not so comfortable place.’

*naagaffanu*      *banna*      *punitsIkaiba*      *nivvaintii*      *aItaryaa*  
 naa-ga-ffa-nu      ban-ø=na      punitsI-ka-iba      niv-vai-n=tii      aI-tar=yaa,  
 true-GEN2-child-NOM2      1SG-DAT1=TOP      hursh-VA-CONJ      sleep-POT-NEG=QT      say-PAST2=TOP

‘In the meantime the true child said “I feel uncomfortable and cannot sleep”,’

*ttyaa*      *vva*      *kuman*      *ttsii*      *nivvi*      *baga*      *umanna*      *nivvaditii*  
 ttyaa      vva      kuma-n      tts-i-i      niv-vi-ø      ba-ga      uma-n=na      niv-va-di=tii  
 then      2SG      here-DAT1      come-INF-SUS      sleep-INF-IMP      1SG-NOM1      there-DAT1=TOP      sleep-IRR-INT=QT

‘“then you come and sleep here, I will sleep there”’

*unu*      *anigamaga*      *kaii*      *nivviutartsa.*  
 unu      ani-gama-ga      kai-i      niv-vi+u-tar=tsa.  
 that      elder.sister-DIM-NOM1      change-SUS      sleep-INF+PRG-PAST2=HS

‘said the elder sister (the stepchild), and she exchanged the place with the true child and slept again.’

*kaii*      *nivviutaryaa*      *unu*      *annaa*      *ttsii*  
 kai-i      niv-vi+u-tar=yaa      unu      anna=a      tts-i-i  
 change-SUS      sleep-INF+PRG-PAST2=TOP      that      mother=TOP      come-INF-SUS

‘After a while, the sisters fell asleep, then the mother woke up and came closer to them,’

*baa*      *kamanna*      *nivvasItaibatii*      *baatti*      *kirii*  
 ba=a      kama-n=na      niv-vas-I-ta-iba=tii      baa=tti      kir-i-i  
 1SG=TOP      there-DAT1=TOP      sleep-CAUS2-FIN-PAST2-CONJ=QT      OMT=QT      kick-INF-SUS

‘and, assuming that her stepchild was sleeping at the outer side, she kicked the one who was sleeping at the outer side,’

*tooriikinkai doofti utusItartsa.*  
*tooriiki-nkai doof=ti utus-I-tar=tsa.*  
 tooriike-DAT2 OMTP=QT drop-FIN-PAST2=HS  
 ‘and she intentionally dropped it into *tooriike*.’

*mamaffaa mmya naugara naaga ffati katamii*  
*mama-ffa=a mmya naugara naa-ga ffa=ti katam-i-i*  
 in.low-child=TOP EMP well true-GEN1 child=QT think-INF-SUS  
 ‘So the mother, assuming that she succeeded in killing her stepchild,’

*mtsInakankai ifkyaa*  
*mtsI+naka-nkai i-f-ø-kyaa*  
 road-middle-DAT2 go-FIN-NON.PAST-CONJ  
 ‘left the place carrying her child on her back (not knowing that it was the stepchild and not the true child), and, coming in the middle of the road,’

*ndziga duunu utugamaatii aItaryaa*  
*ndzi=ga duu-nu utu-gama=a=tii aI-tar=yaa,*  
 which=FOC our-GEN2 younger.sister=TOP=QT say-PAST2=TOP  
 ‘the child on her back said “where’s my younger sister?”’

*gammya uryaa vvadu atarrutii uriubaa utsIkii sItii*  
*gammya ur=yaa vva=du a-tar-ru=tii uri-u=baa utsIk-i-i sIt-i-i*  
 oh.my.god that=TOP 2SG=FOC COP-PAST2-QUE=QT 3SG-ACC=TOP drop-INF-SUS throw-INF-SUS  
 ‘So the mother called out “Oh my god! It was you!”, and she threw the stepchild away,’

*naramai ikii duuftii utii sIntartsa*  
*nara=mai ik-i-i duuf=tii ut-i-i sI-n-tar=tsa*  
 oneself-also go-INF-SUS OMTP=QT fall-INF-SUS die-FIN-PAST2=HS  
 ‘and she ran back to *tooriike*, and threw herself into the water in despair.’

### ABBREVIATIONS

<b>ABL:</b> Ablative case suffix	<b>ACC:</b> Accusative case suffix	<b>ALL:</b> Allative case suffix
<b>ANEG:</b> Adjective negative word	<b>ASUS:</b> Adjectival suspending form derivational suffix	<b>CAUS1/2:</b> Causative suffixes
<b>CLF:</b> Numeral classifier suffix	<b>COND:</b> Conditional suffix (a type of conjunction suffix)	<b>CONJ:</b> Conjunction suffix/enclitic (of many kinds)
<b>COP:</b> Copulative auxiliary	<b>DAT1/2:</b> Dative/locative case suffix	<b>DSC:</b> Discourse enclitic
<b>DIM:</b> Diminutive suffix	<b>EMP:</b> Emphasis adverb	<b>FIN:</b> Finite form derivational suffix
<b>FOC:</b> Focus marker	<b>GEN1/2:</b> Genitive case suffix	<b>HS:</b> Hearsay evidence enclitic
<b>IMP:</b> Imperative attemporal suffix	<b>IND:</b> Indefinite suffix	<b>INF:</b> Infinitive form derivational suffix
<b>INT:</b> Intentional mode suffix (affirmative form)	<b>INT.N:</b> Intentional mode suffix (negative form)	<b>IRR:</b> Irrealis stem derivational suffix
<b>LE:</b> Lower evidentiality suffix	<b>LOC:</b> locative case suffix	<b>NA:</b> Nominal adjective derivational suffix
<b>NEG:</b> Verb negative suffix	<b>NOM1/2:</b> Nominative case suffixes	<b>NON.PAST(1/2):</b> Non-past tense suffix
<b>OMTP:</b> Onomatopoeic word	<b>OPT:</b> Optative mode suffix	<b>PASS:</b> Passive suffix
<b>PAST 1/2:</b> Past tense suffix	<b>PERF:</b> Perfect aspect auxiliary	<b>PL1/2:</b> Plural suffix
<b>POT:</b> Potential suffix	<b>PRG:</b> Progressive aspect auxiliary	<b>QT:</b> Quotation enclitic
<b>QUE:</b> Question suffix/enclitic	<b>RSL:</b> Resultative aspect auxiliary	<b>SUS:</b> Suspending form derivational suffix
<b>TOP:</b> Topic marker	<b>VA:</b> Verbal adjective derivational suffix	<b>1/2/3 SG:</b> First/second/third person singular pronoun
<b>1/2/3 PL:</b> First/second/third person plural pronoun	<b>-:</b> affix boundary	<b>=:</b> clitic boundary
<b>+</b> : root boundary in reduplication and compounding	<b>#:</b> Word boundary (optional)	<b>*</b> : ungrammatical
<b>?</b> : unnatural	<b>A~B:</b> A and B are free variations	<b>A/B:</b> A and B are conditioned variations

### REFERENCES

- Bybee, Joan. 1985. *Morphology: typological studies in language* (vol IX). Amsterdam: John Benjamins.
- Comrie, Bernard. 1978. *Aspect*. 2<sup>nd</sup> printing. Cambridge: Cambridge University Press.
- Foley, William A., and Robert Van Valin Jr. 1984. *Functional syntax and universal grammar*.

Cambridge: Cambridge University Press.

- Kamei, Takashi, Rokuroo Koono, and Eiichi Chino. eds. 1997. *Nipponrettoono gengo* [the languages on Japan archipelago]. Tokyo: Sanseido.
- Nakama, Mitsunari. 1983. Ryukyuu miyakonagahamahoogenno onin [a phonology of Nagahama dialect of Irabu Ryukyuan]. In Inoue, Humio, Kooichi Shinozaki, Takashi Kobayashi, and Takuichiroo Oonishi, eds., *Ryuukyuuhoogen koo* [Some thoughts on Ryukyuan] 7, 198-218, Yumani Shoboo.
- Motonaga, Moriyasu. 1982. Irabuhooogenno kenkyuu [A study of Irabu Ryukyuan]. In Inoue, Humio, Kooichi Shinozaki, Takashi Kobayashi, and Takuichiroo Oonishi, eds., *Ryuukyuuhoogen koo* [Some thoughts on Ryukyuan] 7, 78-97, Yumani Shoboo.
- Nichols, Johanna. 1986. Head-marking and dependent-marking grammar. *Language* 62 (1): 56-119.
- Payne, Thomas E. 1997. *Describing morphosyntax: a guide for field linguists*. Cambridge: Cambridge University Press.
- Ryuukyuu hoogen kenkyuu kurabu. 2004. *Irabu* (Ryuudaihoogen 19). Ryuukyuu hoogen kenkyuu kurabu.
- \_\_\_\_\_. 2005. *Irabu* (Ryuudaihoogen 20). Ryuukyuu hoogen kenkyuu kurabu.
- Sawaki, Motoei. 2000. Miyakohooogenno mondaiten [Controversial topics on Miyako dialect]. *Onseikenkyuu* [Journal of the Phonetic Society of Japan] 4 (1): 36-41.
- Shibata, Takeshi. 1972. *Zenkoku hoogenshiryoo* [National dialect corpus of Japan] (11: Ryukyuu). Nihon Hoosoo Kyookai.
- Silverstein, Michael. 1976. Hierarchy of features and ergativity. In Dixon, R.M.W., ed., *Grammatical categories in Australian languages*, 112-171, Canberra: Australian Institute of Aboriginal Studies.

## 伊良部琉球語の基礎的な文法概説

下地 理則

本論文の目的は、琉球諸語に属し、伊良部島（沖縄県宮古島市）に話者を有する伊良部琉球語の文法概説を行うことである。伊良部琉球語は、話者数が多くても数千人であり、若い世代への継承が行われていないという点で、いわゆる危機言語である。ところがこれまでのところ、伊良部琉球語に関する包括的な文法書は存在せず、文法研究もほとんど行われていない。こうしたことから、伊良部琉球語においては、包括的な記述文法書の作成が早急に求められている。本論文はこうした要請に応えるため、今後の伊良部琉球語の文法書作成を見据えた基礎的な文法概説を行った。すなわち、記述内容を基本的なものに絞りつつも、音韻から統語までを視野に入れ、一般的な記述文法書が備えている項目をできるだけ網羅した。さらに、言語類型論的に重要であろうと考えられる項目もなるべく取り上げた。最後に、伊良部琉球語の文脈付きの例文資料として、論文末尾に筆者の収集した民話テキストを添付した。

(Michinori Shimoji,

Research School of Pacific and Asian Studies, Australian National University)