

Tar Characteristics as Influenced by Air flow Rate Changes in a Downdraft Gasifier

Rizqi Fitri Naryanto

Mechanical Engineering Department, Faculty of Engineering, Universitas Negeri Semarang

Enomoto, Hiroshi

Division of Mechanical Science and Engineering, Graduate School of Natural Science and Technology, Kanazawa University

Mera Kartika Delimayanti

Department of Computer and Informatics Engineering, Politeknik Negeri Jakarta

Ari Dwi Nur Indriawan Musyono

Mechanical Engineering Department, Faculty of Engineering, Universitas Negeri Semarang

他

<https://doi.org/10.5109/6792837>

出版情報 : Evergreen. 10 (2), pp.842-850, 2023-06. 九州大学グリーンテクノロジー研究教育センターバージョン :

権利関係 : Creative Commons Attribution-NonCommercial 4.0 International

Tar Characteristics as Influenced by Air flow Rate Changes in a Downdraft Gasifier

Rizqi Fitri Naryanto^{1*}, Enomoto Hiroshi², Mera Kartika Delimayanti³,
Ari Dwi Nur Indriawan Musyono⁴, Agustien Naryaningsih⁵

¹Mechanical Engineering Department, Faculty of Engineering, Universitas Negeri Semarang, Indonesia

²Division of Mechanical Science and Engineering, Graduate School of Natural Science and Technology, Kanazawa University, Japan

³Department of Computer and Informatics Engineering, Politeknik Negeri Jakarta, Indonesia

⁴Mechanical Engineering Department, Faculty of Engineering, Universitas Negeri Semarang, Indonesia

⁵Fisheries Research Center, BRIN (National Research and Innovation Agency), Indonesia

*Author to whom correspondence should be addressed:

E-mail: rizqi_fitri@mail.unnes.ac.id

(Received January 8, 2023; Revised March 16, 2023; accepted April 6, 2023).

Abstract: Tar, as is well-known, can affect the gasification operating system, so tar generation should be reduced. By adjusting the air flow rate, this study is expected to limit tar generation. This research will use wood pellets to limit the amount of tar produced during gasification. In experiments, wood pellets contained 2% moisture and air flow rates ranged 40, 60 and 80 Liters/min. Gravimetric and Gas chromatography-mass spectrometry measurements were also conducted to evaluate the amount and density of tar. The amount of tar products decreased as the air flow rate increased. According to the research, phenol is the most prevalent component of tar, whereas indene is the least common. When the air flow rate was the highest (80 Liters/min), the least amount of tar was produced. Tar compounds will be used to determine tar quantification. The characteristics of Class 4 (LPH) and Class 5 (HPH) tar were radically changed by increasing the air flow rate.

Keywords: Air flow rate; Gas Chromatography and Mass Spectrometry; Tar Quantification; Tar Characteristics.

1. Introduction

Biomass is a prospective, sustainable, and new renewable energy source that contributes for the overall demand to power and also acts as a fuel source for producing producer gas. Biomass is particularly important in rural areas, where it meets the demand for local energy¹⁻³). Moreover, biomass-to-energy conversion is one of the viable technologies for replacing fossil fuels⁴⁻⁷). Several methods can be used to turn biomass into energy. One of them is gasification, which makes products that are more efficient and have less tar. Gasification is a type of oxidation that usually happens at temperatures above 500 °C. During this process, a solid biomolecule is turned into H₂ and CO^{8,9}).

In biomass innovation, woody biomass, an organic material made from lignin, is used as a feedstock. Using feedstock means that there is not much tar in biomass gasification. This study used wood pellets, a type of woody feedstock because they are easy to get, cheap, and portable¹⁰). To achieve the high efficiency and the lower

tar content, a downdraft gasifier was employed in a gasification process that created producer gas and tar. Some of the hydrocarbons in tar are arranged in five rings, and some of them are aromatic molecules that can be oxygenated, making tar a polycyclic aromatic hydrocarbon (PAH)¹¹⁻¹³). The European Commission's Energy Directorate General (DG XVII), the International Energy Agency (IEA), and the United States Department of Energy (DOE) all use the exact interpretation of tar. It is all hydrocarbon compounds with a molecular mass weight greater more than benzene are included in their definition of tar^{12,14}).

During the gasification process, tar was created when condensable organic compounds interacted with the product gas^{15,16}). It causes severe damage to machinery, as coke forms in exchangers and valves become clogged. Tar should be removed from the biomass system using various methods¹⁷). Since it causes damage and decreases performance. Density measurements of tar components were obtained using Gravimetric Analysis Machine (GA) and also Gas Chromatography and Mass Spectrometry

(GC-MS series QP2010 Plus by Shimadzu, Japan). Tar compounds were categorized based on their molecular weight¹⁸. The chemicals were divided into five categories based on their molecular weight and condensing behavior in this investigation¹⁹⁻²³.

Little research has looked at how air velocity correlates to classifying and quantifying tar^{24,25}. Therefore, this research has purpose to examine the impact of air flow rate on tar quantification and classification. Hiroaki Ohara and Katsuaki Matsumura have a patent for a "Method and Apparatus for Collecting Tar" with patent number JP 2009-40885 was published Patent Office of Japan²⁶. Also, the tar quantification identified the nine chemical compounds as being present in all experiment.

2. Materials

2.1. Feedstock

Since wood pellets were easily accessible and comparable in size to the gasification system equipment utilized in the laboratory, they were utilized in this study. A higher lignin content than competing feedstocks was another factor in its selection. On average, a wood pellet will have about 38 % cellulose, 17 % hemicellulose, 3 % extractive, and 21% lignin.²⁷⁻²⁹ Lignin is a polymer made of aromatic molecules blended with lignocellulosic materials to hold cells together. It helps hydrocarbon products stick together, leading to tar making³⁰. The wood pellet measured 790 kg/m³, and had 6 mm diameter and 12 mm length. We used the Industrial Standard of Japan to guide both the Ultimate Analysis (UA) and the Proximate Analysis (PA). Both UA and PA may be seen in Table 1, with natural feedstock components including C, N, S, H, and O being employed for the qualitative approach. The PA generated many characteristics, including fixed carbon, volatile matter quantification data, and feedstock ash¹⁷.

As a first phase, the research requires drying the feedstock using drying machine techniques (Dryer code TTM-440N by Akira Higashi, Japan). After being dried in the moisture content, the sample's original moisture of around 7 wt.% decreased to about 2 wt.%. The moisture level of the wood pellet feedstock will be checked using moisture analyzer equipment (AND MF-50). Figure 1 (a) and (b) Device the moisture content measurement apparatus.

Table 1: Wood pellet components with Ultimate analysis (UA) and Proximate analysis (PA)

UA (dry ash free, wt. %)	
Japan Industrial Standard M8813	
O (balance)	43.37
H	6.43
S	0.09

N	0.09
C (dry ash-free)	50.02
PA (dry basis, wt. %)	
Japan Industrial Standard M8812	
Volatile Matter (dry base)	81.82
Fixed carbon	17.65
Ash	0.53
Low heating value (LHV)	15.37 MJ/kg-dry

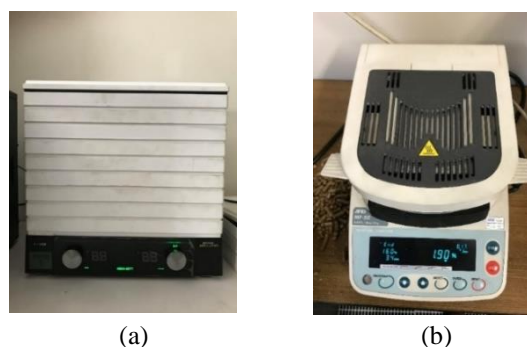

Fig. 1: (a) The use of a tool Drying Machine (Dryer code TTM-440N by Akira Higashi, Japan) (b) Device for Analysing Moisture (MF-50 production of AND company)

3. Methods

3.1. Gasifier System

A schematic representation of the downdraft gasifier system is shown in Figure 2. A gasifier, a chiller, a suction pump, a soot remover, and a buffer tank make up the GC-MS series QP2010 Plus by Shimadzu Japan, apparatus used for analysis. The stainless-steel downdraft gasifier had a 500 mm height and an interior diameter of 120.8 mm. Only activated carbon should be employed in the gasifier because it is the only material that can remove the tar from producing gas. Thus, the shot removal apparatus utilized in the experimental gasifier system is 1200 mm in height and 320 mm in internal diameter. Figure 2 show the downdraft gasifier diagram of experimental apparatus used in the research.

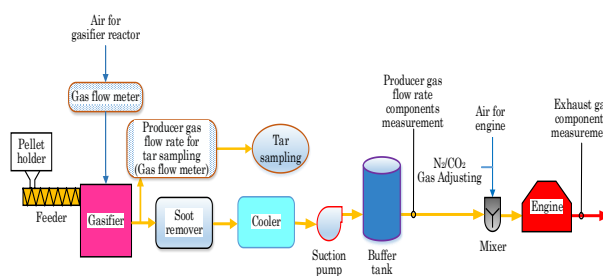

Fig. 2: The downdraft gasifier system block diagram

Seventeen thermocouples with K-type were installed as a set of temperature monitors for the interior. The

thermocouple with K-type must be placed close to the gasifier's wall to stop the wood pellets from shifting. The figure of gasifier system with the seventeen thermocouples was shown in Figure 3 and Figure 4 depicts the temperature distribution indicated by the thermocouple.

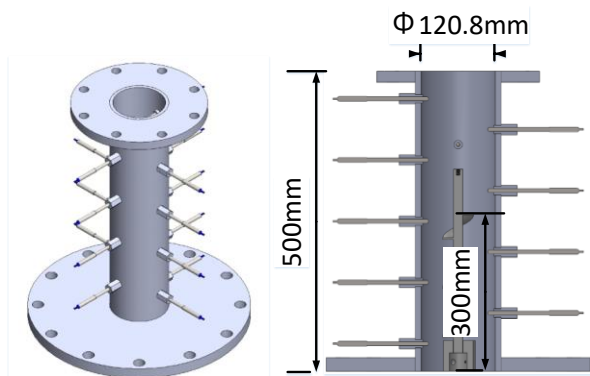

Fig. 3: The Gasifier with Thermocouples

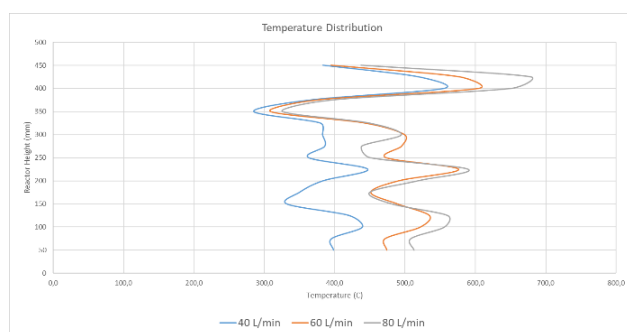

Fig. 4: Temperature Distribution

We used a GL 820 data logger (Ohio, USA., production of Data Instruments Inc.) to track the gasifier's operating temperature, which ranged from about 400 to 600 °C. The cooler was used to reduce the temperature of the producer gas before the suction pump pulled it into the buffer tank. The suction pump collected all the newly created gas and stored it in the buffer tank. Compounds in the producer gas were recognized and quantified by utilizing gas chromatography and mass spectrometry with a TCD, Argon carrier gas and Micro GC Agilent 490. The original use of a reaction chamber was as a holding area before the fuel or energy contained within it was put to use in the vehicle's engine or other machinery^{31,32}.

This investigation used a gasification workplace with approximately 2% humidity and air flow rate at 40, 60, and 80 Liters/min. Environment air in the air flow rate was monitored at 40 Liters/min, and 60 Liters/min, and also 80 Liters/min using a gas flow meter at the gasifier's top. The process was capped off by adding wood pellets with the moisture content around 2% weight, which the gasifier dried. The dry wood pellet was fed at a feed rate 5 kg/h periodically³³. In previous studies, it was determined that wood pellets with low moisture content are preferable for

operation because, with low moisture content, the gasification process produces less tar, and tar can cause serious damage to the gasification equipment.

The equivalence ratio (ER) in gasification refers to the ratio of the actual air/fuel ratio to the stoichiometric air/fuel ratio required for complete combustion. The equivalence ratio can be calculated in equation (1).

$$ER = \frac{(\text{actual air/fuel ratio})}{(\text{stoichiometric air/fuel ratio})} \quad (1)$$

In the gasification of biomass, the stoichiometric air/fuel ratio is typically around 0.25-0.3 (kg of air/kg of biomass), depending on the composition of the biomass. Assuming a biomass feed rate of 1 kg/min, the air flow rates of 40, 60, and 80 Liters/min correspond to air/fuel ratios of 40 Liter/min = 0.0533 kg air/kg biomass, ER = 0.178, and 60 Liter/min = 0.08 kg air/kg biomass, ER = 0.267, and also 80 Liter/min = 0.1067 kg air/kg biomass, ER = 0.356.

3.2. Tar Sample and Composition of Tar

We analysed the tar using Gravimetric and Cold Solvent Trapping method (CST) in this probe. The CST method was tested to sample of gasifier as long as gasification process. Ethylene glycol used in CST method as a solvent and also GC-MS was used to analyse the results^{34,35}. Ethylene glycol can work at temperatures between 250 °C and -20 °C; however, we require temperatures below zero to capture tar. Tar's density is employed in the gravimetric measurement of tar's composition.

Different air flow rates of 40 Liters/min, 60 Liters/min, and 80 Liters/min allowed for a simultaneous differentiation in moisture content around 2% weight was used in the experiment. Tar samples were collected between the gasifier and the soot remover. The gasifier uses more than 600 °C to create the "clinker". Since this was an experiment, the temperature was kept between 400 and 600 °C by use control system, which is the gasification process can be automated using a control system that regulates the temperature by adjusting the flow rate of the feedstock, the amount of air supplied, and the quantity of ash removed. The second way is Gasification Chamber Design, which proper design of the gasification chamber, including its size and shape, can help to maintain a uniform temperature and reduce temperature fluctuations.

Clinkering occurs during the gasifier's biomass gasification process when ash melts and fuses into a complicated, glassy slag. In addition, ash occurs when the powdery residue of burned wood pellets is not combusted. This clinker can sometimes obstruct the feed movement, disrupting the gasifier's regular operation^{36,37}. Using a methodology that differs from that described in the draft Tar Protocol CEN/TS 143:2005, tar samples were collected³⁴. With circulating gas, the CEN/TS 143:2005 standard applies the principle of liquid quench. The impinger's bottles were split in half so one half could be

heated while the other half could be chilled. This study used the patented Apparatus, Method Collecting Tar. It was found by Katsuaki Matsumura and Hiroaki Ohara with Patent from Patent Office of Japan number 2009-40885²⁶⁾.

The impingers bottles with a total of three bottles are used to defrost the gas production from gasification process from downdraft gasifier, catching tar sample in gas phase using a contact surface method with glass beads. Using this new technique can reduce the temperature of the producer gas from maximum 250 °C to below -20 °C, allowing for the collection of a representative sample of tar. Impinger bottles are used to collect tar samples during the gasification process; these bottles are easier to handle and clean.

The tar collecting apparatus is shown in Figure 5. This device removes ash, dust, and soot from the tar sample by heating the producer gas to 250 °C. Three bottle vials were used for collecting tar, each measuring bottle have dimension in 300 mm total length and also 24 mm diameter in wide. In order to contain the tar sample in manufacturing gas, 30 ml of glass beads were added to each container (AS ONE BZ-2, 1.5-2.5 mm). Glass beads are used to increase the tar's contact area in the sampling bottles before the tar is chilled to -20 °C in a dewar vessel containing ethylene glycol as an antifreeze. In this experiment, tar samples were collected using a gasification system after a gasifier, and before soot remover had been run, with the flow rate of producer gas maintained at 8 Liters/min for the duration of the sampling period of 20 minutes.

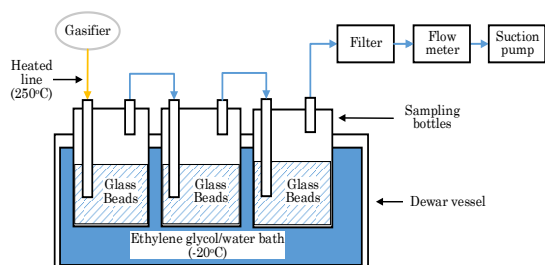

Fig. 5: Equipment for Tar Sampling

In this work, we used gas chromatography and mass spectrometry tool (GC-MS) to analyze tar's chemical compounds, and we used reference reagents with purities ranging from 94% to 99% to the standard. The presence of phenol compound, toluene compound, naphthalene compound, indene compound, fluorene compound, biphenyl compound, fluoranthene compound, and pyrene compound in a 2 ml vial bottle of tar was identified using GC-MS QP2010 Plus by Shimadzu, Japan. The purity of a product can be measured by using nine standards chemical compounds in a total ion chromatogram (TIC). Tar chemicals were identified using a peak similarity index greater than 70³⁸⁻⁴⁰⁾. In addition, GC Postrun software was used to examine the GC-MS data in order to determine the presence of tar component in the sample of

gasification process.

3.3. Method of Gravimetric Analysis

Method of Gravimetric analysis is a method for determining an exact density value for the material under investigation. The process of distillation and evaporation reveals the substance's pure bulk. This technique analyses the purified mass compound to determine the overall mass percentage. Tar samples with 2 % water content and varying air flow rates were analyzed using the gravimetric method. At a temperature of 65 °C, the solvents were removed from the tar samples. Here, we heat 3 grams of the tar-acetone mixture at 65 °C for 5 hours. This is because, at around 56 °C, acetone begins to evaporate. Only a pure mass of tar, often called tar density, is left in the remnant.

4. Results and Discussion

4.1 Effect of Air flow Rate on Tar Quantification

This analysis compared three conditions of air flow rate to constant moisture content. An air flow rate of fuel is one of most important features since it affects the composition of producer gas and in tar formation⁴¹⁾. The biomass consumption rate rose with an increase in air flow rate from 40 Liters/min to 80 Liters/min. By increasing the air flow rate, more oxygen was introduced into the gasifier, allowing a greater quantity of biomass to be burned. The released energy sped up the gasification process⁴²⁾. Phenol compound (C₆H₅OH), toluene compound (C₇H₈), indene compound (C₉H₈), naphthalene compound (C₁₀H₈), biphenyl compound (C₁₂H₁₀), fluorene compound (C₁₃H₁₀), phenanthrene compound (C₁₄H₁₀), fluoranthene compound (C₁₆H₁₀), and also pyrene compound (C₁₆H₁₀) was among the tar components that were measured quantitatively in this study²⁸⁾. Because all of these substances were consistently detected in every single test.

The concentration of the tar was determined by weighing it in this experiment, as shown in equation (2) below:

$$C_t = \frac{W_t}{V_s} \quad (2)$$

C_t is the amount of gas produced (g/Nm³), W_t its mass of gas (g), and V_s its volume of gas (Nm³). The predicted tar concentration from these investigations is depicted in Figure 6.

The effects of air flow rate around on 2 % wt. moisture content were tested at 40 Liters/min, 60 Liters/min, and 80 Liters/min. The moisture content was constant although air flow rate change. As can be observed in Figure 6, tar components were present in the majority of samples. Tar was mainly concentrated in phenol compound (C₆H₅OH) because wood pellets included oxygen-rich compounds such as lignin, cellulose, and hemicellulose. However, tar concentrations for toluene compound (C₇H₈) and indene compound (C₉H₈) remained very low across various

operating condition of gasification.

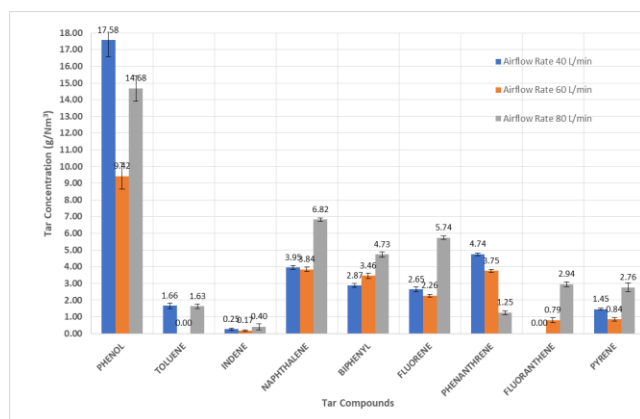
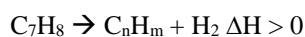

Fig. 6: Tar production on the moisture content of 2 wt.% at varying air flow rates of 40 Liters/min, 60 Liters/min and 80 Liters/min

Phenol compound (C_6H_5OH), naphthalene compound ($C_{10}H_8$), biphenyl compound ($C_{12}H_{10}$), and fluorene compound ($C_{13}H_{10}$) were all present in very high concentrations throughout this study. At a flow rate of 40 Liters/min, the tar content in phenol compound (C_6H_5OH) is 17.58 ± 0.97 g/Nm³. A steady rise in air flow rate from 40 Liters/min to 80 Liters/min and a rise in tar concentration from 3.95 ± 0.12 g/Nm³ to 6.82 ± 0.11 g/Nm³ led to a rise in naphthalene compound ($C_{10}H_8$) levels. Increasing the air flow rate from 40 Liters/min to 80 Liters/min and the tar concentration from 2.87 ± 0.12 g/Nm³ to 4.73 ± 0.17 g/Nm³ led to a linear increase in biphenyl compound ($C_{12}H_{10}$) at a moisture content of 2 wt.%. This is because as gasifier temperature increased, phenolic chemicals in the tar gave way to non-substituted Polyaromatic Hydrocarbon (PAH). Also, since the combustion in the reactor was erratic, the tar content increase^{19,43}. Since most tar components are light polyaromatic compounds, an increase in temperature causes an increase in the concentration of naphthalene compound ($C_{14}H_{10}$), biphenyl compound ($C_{12}H_{10}$), and fluorene compound ($C_{13}H_{10}$) in the tar generated.

Indene compound (C_9H_8), a light polyaromatic hydrocarbon, was among those found in low concentration. Small molecular gases were created by oxidizing the toluene compound (C_7H_8) and indene compound (C_9H_8). As demonstrated in the chemical reaction below, the tar compound created a tar deposit, which prevented the formation of toluene (C_7H_8).



Most of the toluene compound (C_7H_8) was fractured, so there was not much of it, but the free radical created by the partial breakdown of the light hydrocarbon aromatic molecule was polymerized to form a wide variety of macromolecular compounds (C_nH_m). Tar compound deposition describes this phenomenon.

4.2 Effect of Air flow Rate on Classification of Tar

The presence of tar is indicated by gasification by products and molecular weights greater than benzene in heavy hydrocarbons⁴⁴. The Dutch Agency for Research in Sustainable Energy (SDE) funded a study titled "Primary measures for the lowering of tar formation in the fluidized-bed gasifier", categorizing tar by molecular weight. Natural Science Research Organization (TNO) and the University of Twente (UT) worked together on this²⁰. The molecular weight-based tar classification is listed in Table 2. Earlier studies have already established the distinction between condensable tar and non-condensable tar. Condensable tars were found to cause filter pore damage, coke formation and clogging, and condensation in cold environments. This caused widespread disruptions in activities, including sanitation and power generating. Due to its polluting effects, this kind of tar must be eliminated from gasification process⁴⁵.

Table 2: Molecular weight-based categorization of different types of tar²⁰

Tar Class	Property
Class 1 Gas Chromatography undetectable heaviest tars	This class of substances condenses at high temperatures and low concentrations.
Class 2 Heterocyclic aromatic compounds	This class contains compounds having a high-water solubility, such as phenol, pyridine, isoquinoline, cresols, dibenzophenol, and quinolone.
Class 3 Light hydrocarbon aromatic compounds (1 ring)	This class includes ethylbenzene, toluene, styrene, and xylenes, which have excellent condensability and solubility.
Class 4 Light polyaromatic hydrocarbon compounds (2-3 rings)	Indene, naphthalene, biphenyl, methylnaphthalene, acenaphthalene, anthracene, fluorene, phenanthrene, and other members of this class condensate at low temperatures even at extremely low concentrations.
Class 5 Heavy polyaromatic hydrocarbon compounds (4-7 rings)	Fluoranthene, chrysene, pyrene, coronene, and perylene are examples of compounds that condense at high temperatures and low concentrations.

The gasification method was sensitive to the tar's characteristics and chemical make-up. Tar's Class 2, 4, and 5 condensation-causing components provide engine and turbine fouling risks. Therefore, the problem in utilizing producer gas is eliminating or transforming classes 2, 4, and 5 via chemical processes. This study classified the gasification operating parameters that reduced tar compound generation by changing the air flow rate. Table 3 shows that Class 1 tar has no measurable levels of any compounds measured by Gas Chromatography and Mass Spectrometry (GC-MS). GC-MS cannot detect the thickest tar due to the low concentration of chemicals that condense at high temperatures.

Tar Compounds like phenol compound, part of class 2, are heterocyclic aromatic compounds (C_6H_5OH). Toluene compound (C_7H_8) is in class 3, and indene compound (C_9H_8), naphthalene compound ($C_{10}H_8$), biphenyl compound ($C_{12}H_{10}$), fluorene compound ($C_{13}H_{10}$), and phenanthrene compound ($C_{14}H_{10}$) are also involved in class 4. Finally, fluoranthene compound ($C_{16}H_{10}$) and pyrene compound ($C_{16}H_{10}$) are examples of chemicals in class 5.

The molecular weight distribution of tar in three different conditions with various air flow rate and constant moisture content is shown in Figure 5. Class 2 has a concentration of 17.58 ± 0.72 g/Nm³, and Class 4 has a concentration of 18.93 ± 2.37 g/Nm³ at an air flow rate of 80 Liters/min when using a moisture content of 2 wt.% as shown in Figure 7. Unlike classes 2 and 1, the value of tar typically increases with higher categorization in classes 3, 4, and 5. Class 4 tar had the highest value because of the chemical reaction in the gasification system, which was disrupted by an increasing air in the gasifier. According to data on the correlation between air flow rate and total PAH concentrations, PAH concentrations in classes 4 and 5 rose dramatically with increasing air flow rates. The results of this study demonstrated that a high air flow rate contributes to an increase in tar concentration across practically all classes.

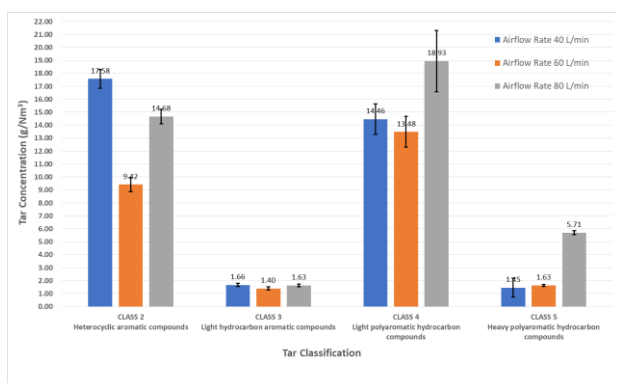

Fig. 7: Classification of tar according to molecular weight, with a moisture content of 2 wt.% at air flow rates of 40, 60, and 80 Liters/min respectively

4.3. Effect of Air flow Rate on Tar Density

Studying the tar protocol led to the introduction of a new solution to the tar problem. Protocol components include a uniform sampling and analysis plan for gasification plant tar. This protocol aids in the development of other gravimetric techniques for determining the compound's identity. This research makes extensive use of gas chromatography and gravimetric analysis based on the tar procedure standard. Gravimetric measurements of tars are accomplished by evaporating tar components and distilling solvents like acetone^{8,39,46,47}.

A gravimetric analysis was utilized to determine the tar density in this study. Distillation, which relies on the solvent and water's different boiling points, is central to the gravimetric principle. To determine the tar density, the amount of tar in the producer gas must be calculated using the following equation (3).

$$vol_{tar} = FR_{producer\ gas} \cdot t_{producer\ gas} \quad (3)$$

The Variable vol_{tar} is volume of tar in the total of producer gas in sample (Liter), $FR_{producer\ gas}$ is flow rate producer gas (Liter/min), and also $t_{producer\ gas}$ is producer gas sampling time (min).

Equation (4) can be used to calculate the density of tar in producer gas.

$$\rho_{tar} = \frac{m_{tar}}{vol_{tar}} 1000 \quad (4)$$

Where ρ_{tar} is tar density in producer gas (mg/m³), m_{tar} is the mass of tar in the sample amount of producer gas (mg), vol_{tar} is the volume of tar in total amount of producer gas in sample (L).

Figure 7 shows the results of gravimetric analysis of biomass wood pellets. Gravimetric analysis of the relationship between air flow rate and tar density was performed for three different air flow rates (40 Liters/min, 60 Liters/min, and 80 Liters/min). At a rate of 40 Liters/min and a moisture content around of 2 wt.%, the highest density of the tar was 13646 mg/m³. This value decreased to 10123 mg/m³ in air flow rates of 60 Liters/min and 7772.5 mg/m³ in air flow rates of 80 Liters/min⁴⁸). These conditions occurred as a result of the uniformity of the temperature inside the gasifier as a result of increasing the amount of air in the gasifier by increasing the air flow rate⁴⁹). It resulted in complete gasification of all wood pellet feedstock. All of the wood pellet feedstock was gasified. A higher air flow rate (80 Liters/min) during gasification allows for less tar to be formed. Therefore, it is important to optimize the air flow rate during gasification to balance between the heating value of the gas and the gas yield. In general, a higher air flow rate may result in a gas with a higher heating value, but the overall gas yield may be reduced. On the other hand, a lower air flow rate may result in a lower heating value gas but with a higher gas yield.

In addition to reducing the formation of tar, increasing the air flow rate during gasification can also have an effect on the heating value of the produced gas

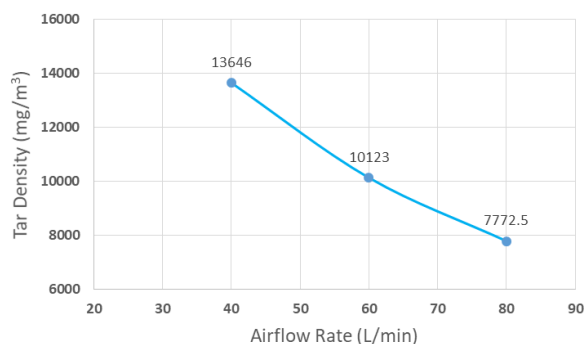

Fig. 7: Tar density on 2 wt.% moisture content at air flow rates of 40 Liters/min, 60 Liters/min, and 80 Liters/min

5. Conclusions

There were many variations of gasification operation parameters used to complete the process. Some researchers used constant relative humidity, whereas others varied the air flow rate. The results of this study justify concluding about:

- ✓ Since oxygen-rich materials like cellulose and lignin make up the bulk of wood pellets, the majority of their tar components have high concentrations of phenols.
- ✓ The value of air flow rate influenced the tar concentration, so an increase in air flow rate resulted in a higher tar concentration of PAH in classes 4 and 5.
- ✓ Air flow rate of 80 Liters/min produced the minor of tar. A cost of gasification process and longevity of gasification are both impacted by the minimum tar density required to sustain the gasification system. Therefore, the gasification product might be used to ignite internal combustion engines (ICE).

Acknowledgements

The authors express their gratitude to Universitas Negeri Semarang for the funding research and publication with grant number B/347/UN37/HK/2022. The authors are also grateful to Kanazawa University Japan for the data analysis.

References

1) Y. Furutani, K. Norinaga, S. Kudo, J. Hayashi, and T. Watanabe, "Current situation and future scope of biomass gasification in japan," *Evergreen*, **4** (4) 24–29 (2017). doi:10.5109/1929681.

2) M.M. Rahman, S. Saha, M.Z.H. Majumder, T.T. Suki, M.H. Rahman, F. Akter, M.A.S. Haque, and M.K. Hossain, "Energy conservation of smart grid system using voltage reduction technique and its challenges,"

EVERGREEN Joint Journal of Novel Carbon Resource Sciences & Green Asia Strategy, **09** (04) 924–938 (2022). doi.org/10.5109/6622879

- 3) A. Wahid, R. Mustafida, and A. Husnil, "Exergy analysis of coal-fired power plants in ultra supercritical technology versus integrated gasification combined cycle," *Evergreen*, **7** (1) 32–42 (2020). doi:10.5109/2740939.
- 4) A. Kasaeian, "EVALUATING integration of biomass gasification process with solid oxide fuel cell and torrefaction process," *Journal of Thermal Engineering*, 230–239 (2019). doi:10.18186/thermal.654637.
- 5) Janter Pangaudan Simanjuntak, Khaled Ali Al-attab, Eka Daryanto, Bisrul Hapis Tambunan, and Eswanto, "Bioenergy as an alternative energy source: progress and development to meet the energy mix in indonesia," *ARFMTS*, **97** (1) 85–104 (2022). doi:10.37934/arfmts.97.1.85104.
- 6) A. Rahman, Nining Betawati Prihantini, and Nasruddin, "Biomass production and synthesis of biodiesel from microalgae *synechococcus* hs-9 (cyanobacteria) cultivated using bubble column photobioreactors," *Evergreen*, **7** (4) 564–570 (2020). doi:10.5109/4150507.
- 7) R. Muhammad, and S. Adityosulindro, "Biosorption of brilliant green dye from synthetic wastewater by modified wild algae biomass," *Evergreen*, **9** (1) 133–140 (2022). doi:10.5109/4774228.
- 8) R. Chodkiewicz, B. Donevski, J. Krzton, and J. Porochnicki, "RECOVERED gas turbine integrated with the pfbc combined cycle power plant," *Strojniški Vestnik - Journal of Mechanical Engineering*, **47** (8) 6 (2001).
- 9) Mohammed Raad Abdulwahab, Khaled Ali Mohammad Al-attab, and Mohamad Yusof Idroas, "Design and characteristics of a new pre-evaporation chamber geometry for low-grade palm oil fuel evaporation for micro gas turbine application," *ARFMTS*, **94** (2) 184–199 (2022). doi:10.37934/arfmts.94.2.184199.
- 10) E. Yustanti, A. Muharman, and A.T. Mursito, "The effect of wood tar and molasses composition on calorific value and compressive strength in bio-coke briquetting," *International Journal of Renewable Energy Development*, **11** (3) 600–607 (2022). doi:10.14710/ijred.2022.39298.
- 11) K. Jirakulsomchok, T. Wongchang, and K. Prasartthong, "Experimental study of combustion of low-calorific producer gas from small scale biomass gasification within porous burner," *Journal of Thermal Engineering*, 1344–1352 (2021). doi:10.18186/thermal.990017.
- 12) K. Maniatis, and A.A.C.M. Beenackers, "Tar protocols. ica bioenergy gasification task," *Biomass and Bioenergy*, **18** (1) 1–4 (2000).
- 13) A.T. Wijayanta, A. Saiful, K. Nakaso, and J. Fukai,

- “Detailed reaction mechanisms of coal volatile combustion: comparison between without soot and soot models,” *Journal of Novel Carbon Resource Sciences*, **2** 8–11 (2010).
- 14) T.A. Milne, R.J. Evans, and N. Abatzoglou, “Biomass Gasifier “Tars””: Their Nature, Formation, and Conversion,” 1998. doi:10.2172/3726.
 - 15) C.A. Jordan, and G. Akay, “Occurrence, composition and dew point of tars produced during gasification of fuel cane bagasse in a downdraft gasifier,” *Biomass and Bioenergy*, **42** 51–58 (2012). doi:10.1016/j.biombioe.2012.03.014.
 - 16) H. Dafiqurrohman, D. Kosasih, A.W.N. Putra, I.B. Setyawan, and A. Surjosatyo, “Improvement of tar removal performance in biomass gasification using fixed-bed biomass filtration,” **52** (4) 19 (2020).
 - 17) S.-W. Park, S.-Y. Lee, Y.-O. Jeong, G.-H. Han, and Y.-C. Seo, “Effects of oxygen enrichment in air oxidants on biomass gasification efficiency and the reduction of tar emissions,” *Energies*, **11** (10) 2664 (2018). doi:10.3390/en11102664.
 - 18) R.J. Evans, and T.A. Milne, “Molecular characterization of the pyrolysis of biomass. 2. applications,” *Energy Fuels*, **1** (4) 311–319 (1987). doi:10.1021/ef00004a001.
 - 19) S. Chianese, S. Fail, M. Binder, R. Rauch, H. Hofbauer, A. Molino, A. Blasi, and D. Musmarra, “Experimental investigations of hydrogen production from co catalytic conversion of tar rich syngas by biomass gasification,” *Catalysis Today*, **277** 182–191 (2016). doi:10.1016/j.cattod.2016.04.005.
 - 20) L. Devi, K.J. Ptasiński, F.J.J.G. Janssen, S.V.B. van Paasen, P.C.A. Bergman, and J.H.A. Kiel, “Catalytic decomposition of biomass tars: use of dolomite and untreated olivine,” *Renewable Energy*, **30** (4) 565–587 (2005). doi:10.1016/j.renene.2004.07.014.
 - 21) A. Pirc, M. Sekavčnik, and M. Mori, “Universal model of a biomass gasifier for different syngas compositions,” *SV-JME*, **58** (5) 291–299 (2012). doi:10.5545/sv-jme.2011.101.
 - 22) Hafnee Latch, Juntakan Taweekun, Kittinan Maliwan, Zainal Alimuddin Zainal Alauddin, and Sukritthira Rattanawilai, “The removal of biomass tar derived producer gas by means of thermal and catalytic cracking methods,” *ARFMTS*, **88** (2) 147–156 (2021). doi:10.37934/arfmts.88.2.147156.
 - 23) H. Latch, J. Taweekun, K. Maliwan, and A. Ishak, “The removal of mixed tar in biomass fuel gas through the thermal and catalytic treatment methods: review,” *IOP Conf. Ser.: Mater. Sci. Eng.*, **1003** (1) 012141 (2020). doi:10.1088/1757-899X/1003/1/012141.
 - 24) J. Fukai, “SENSITIVITY analysis of coal gasification in two-stage entrained-flow gasifier: syngas and carbon conversion prediction,” *Journal of Thermal Engineering*, **3** (6) 1574–1587 (2017). doi:10.18186/journal-of-thermal-engineering.353727.
 - 25) P. Chankapure, P. Doggali, K. Motghare, S. Waghmare, S. Rayalu, Y. Teraoka, and N. Labhsetwar, “Coal and biomass based fuels in rural india: emissions and possibility of their control,” *Journal of Novel Carbon Resource Sciences*, **4** 8–12 (2011).
 - 26) H. Ohara, and K. Matsuzawa, “Method and apparatus for repairing tar JP 2009-40885,” JP 2009-040885, 2009. <https://www.j-platpat.inpit.go.jp/c1800/PU/JP-2007-207391/F1A915D9A45E9E7DAFCE569F7E33F799406F7C84AFAD38B7774536F153ED103F/10/ja>.
 - 27) D.R. Nhuchhen, P.K. Basu, and B. Acharya, “A comprehensive review on biomass torrefaction,” *International Journal of Renewable Energy*, 1–56 (2014).
 - 28) D. Tarasov, M. Leitch, and P. Fatehi, “Lignin-carbohydrate complexes: properties, applications, analyses, and methods of extraction: a review,” *Biotechnology for Biofuels*, **11** (1) 269 (2018). doi:10.1186/s13068-018-1262-1.
 - 29) T. Seljak, M. Kunaver, and T. Kutrašnik, “Emission evaluation of different types of liquefied wood,” *SV-JME*, **60** (4) 221–231 (2014). doi:10.5545/sv-jme.2013.1242.
 - 30) A.G. Buekens, and H. Huang, “Catalytic plastics cracking for recovery of gasoline-range hydrocarbons from municipal plastic wastes,” 19 (1998).
 - 31) R.F. Naryanto, H. Enomoto, V.C. Anh, K. Fukadu, S. Iwai, and R. Noda, “Investigation of producer gas biomass gasification on reciprocated internal combustion engine,” *IOP Conf. Ser.: Earth Environ. Sci.*, **460** 012016 (2020). doi:10.1088/1755-1315/460/1/012016.
 - 32) R.F. Naryanto, H. Enomoto, A. Vo Cong, K. Fukadu, Z. Zong, M.K. Delimayanti, C. Chunti, and R. Noda, “The effect of moisture content on the tar characteristic of wood pellet feedstock in a downdraft gasifier,” *Applied Sciences*, **10** (8) 2760 (2020). doi:10.3390/app10082760.
 - 33) M. Telaumbanua, “Effect of torrefaction temperature on physical properties of biopellet from variant biomass waste,” *IJRER*, (Vol12No1) (2022). doi:10.20508/ijrer.v12i1.12651.g8375.
 - 34) S. Osipovs, “Comparison of efficiency of two methods for tar sampling in the syngas,” *Fuel*, **103** 387–392 (2013). doi:10.1016/j.fuel.2012.05.021.
 - 35) S. Kudo, K. Norinaga, and J. Hayashi, “Applications of catalysis in the selective conversion of lignocellulosic biomass by pyrolysis,” *Journal of Novel Carbon Resource Sciences*, **6** 1–8 (2012).
 - 36) H. Siddiqui, S.K. Thengane, S. Sharma, and S.M. Mahajani, “Revamping downdraft gasifier to minimize clinker formation for high-ash garden waste as feedstock,” *Bioresour Technol*, **266** 220–231 (2018). doi:10.1016/j.biortech.2018.06.086.
 - 37) S.K. Thengane, A. Gupta, and S.M. Mahajani, “Co-gasification of high ash biomass and high ash coal in

- downdraft gasifier,” *Bioresour Technol*, **273** 159–168 (2019). doi:10.1016/j.biortech.2018.11.007.
- 38) R.F. Naryanto, H. Enomoto, V.C. Anh, C. Chunti, and R. Noda, “4-2 effect of tar formation on biomass downdraft gasification reactor of wood pellet with variation of moisture content,” *2019*, **2** (2019).
- 39) R.F. Naryanto, H. Enomoto, N. Hieda, Y. Teraoka, C. Chunti, and R. Noda, “The influence of wood pellet feedstock water content on tar component in biomass system using downdraft gasifier,” *J. Jpn. Inst. Energy*, **98** (5) 115–118 (2019). doi:10.3775/jie.98.115.
- 40) B. Zhou, A.B. Dichiara, Y. Zhang, Q. Zhang, and J. Zhou, “Tar formation and evolution during biomass gasification: an experimental and theoretical study,” *Fuel*, (2018).
- 41) Y.-K. Kim, J. Miyawaki, I. Mochida, and S.-H. Yoon, “Tar reforming of lignite at low temperatures using supported potassium carbonate,” *Journal of Novel Carbon Resource Sciences*, **5** 1–4 (2012).
- 42) P.N. Sheth, and B. Babu, “Experimental studies on producer gas generation from wood waste in a downdraft biomass gasifier,” *Bioresour Technol*, **100** (12) 3127–3133 (2009). doi:10.1016/j.biortech.2009.01.024.
- 43) D.D. Stojiljkovic, V.V. Jovanovic, M. Radovanovic, N.G. Manic, I.R. Radulovic, and S.V. Perisic, “Investigations of combustion process in stove fired on biomass,” in: *Proceeding of Thermal Sciences 2004. Proceedings of the ASME - ZSIS International Thermal Science Seminar II*, Begellhouse, Bled, Slovenia, 2004: pp. 573–577. doi:10.1615/ICHMT.2004.IntThermSciSemin.700.
- 44) S. Chianese, J. Loipersböck, M. Malits, R. Rauch, H. Hofbauer, A. Molino, and D. Musmarra, “Hydrogen from the high temperature water gas shift reaction with an industrial fe/cr catalyst using biomass gasification tar rich synthesis gas,” *Fuel Processing Technology*, **132** 39–48 (2015). doi:https://doi.org/10.1016/j.fuproc.2014.12.034.
- 45) Y. Shen, and K. Yoshikawa, “Recent progresses in catalytic tar elimination during biomass gasification or pyrolysis—a review,” *Renewable and Sustainable Energy Reviews*, **21** 371–392 (2013). doi:10.1016/j.rser.2012.12.062.
- 46) S. Vakalis, F. Patuzzi, K. Moustakas, A. Sotiropoulos, D. Malamis, and M. Baratieri, “Analysis of tar compounds and quantification of naphthalene from thermal treatment of household biowaste.,” *J Environ Manage*, **216** 153–159 (2018). doi:10.1016/j.jenvman.2017.04.063.
- 47) N. Pichet, “Combustion and kinetics parameters investigation of raw and torrefied cocoa pod shells by thermogravimetric analysis,” *IJRER, (ijrer.v11i1)* (2021). doi:10.20508/ijrer.v11i1.11631.g8112.
- 48) R. Fitri Naryanto, M.K. Delimayanti, K. Kriswanto, A.D.N.I. Musyono, I. Sukoco, and M.N. Aditya, “Development of a mobile expert system for the diagnosis on motorcycle damage using forward chaining algorithm,” *IJECS*, **27** (3) 1601 (2022). doi:10.11591/ijeecs.v27.i3.pp1601-1609.
- 49) M. Yahya, H. Fahmi, S. Hadi, and E. Edison, “Performance analyses on fluidized bed dryer integrated biomass furnace with and without air preheater for paddy drying,” *IJPEDS*, **10** (3) 1555 (2019). doi:10.11591/ijpeds.v10.i3.pp1555-1563.