

Automorphic functions for the Whitehead-link-complement group

Matsumoto, Keiji
Department of Mathematics, Hokkaido University

Nishi, Haruko
Department of Mathematics, Kyushu University

Yoshida, Masaaki
Department of Mathematics, Kyushu University

<http://hdl.handle.net/2324/3335>

出版情報 : Kyushu University Preprint Series in Mathematics, 2005-02-08. 九州大学大学院数理学研究
院

バージョン :

権利関係 :



Automorphic functions for the Whitehead-link-complement group

Keiji Matsumoto, Haruko Nishi and Masaaki Yoshida

February 8, 2005

Dedicated to Professor Takeshi Sasaki on his sixtieth birthday

Abstract

We construct automorphic functions on the real 3-dimensional hyperbolic space \mathbb{H}^3 for the Whitehead-link-complement group $W \subset GL_2(\mathbb{Z}[i])$ and for a few groups commensurable with W . These automorphic functions give embeddings of the orbit spaces of \mathbb{H}^3 under these groups, and arithmetical characterizations of them.

Keywords: Whitehead link, hyperbolic structure, automorphic forms, theta functions.

MSC2000: 11F55, 14P05, 57M25

Contents

1	Introduction	2
2	A hyperbolic structure on the complement of the Whitehead link	3
3	Discrete subgroups of $GL_2(\mathbb{C})$, especially Λ	5
4	Symmetry of the Whitehead link	7
4.1	Symmetries of L	7
4.2	Fixed loci	9
5	Orbit spaces under \check{W}, $ST_0(1+i)$ and Λ	10
5.1	The orbifold \mathbb{H}^3/\check{W}	10
5.2	The orbifold $\mathbb{H}^3/ST_0(1+i)$	11
5.3	The orbifold \mathbb{H}^3/Λ	11
6	Theta functions	12
6.1	Theta functions on \mathbb{D}	13
6.2	Embedding of \mathbb{H}^3 into \mathbb{D} and the pull-back of the theta functions . . .	14
6.3	Automorphic functions for $\Gamma^T(2)$ and an embedding of $\mathbb{H}^3/\Gamma^T(2)$. . .	15
6.4	Automorphic functions for Λ and an embedding of \mathbb{H}^3/Λ	16

7 Automorphic functions for W	17
7.1 Fundamental properties of Φ_1, Φ_2 and Φ_3	17
7.2 Isotropy subgroups	18
7.3 An arithmetical characterization of the Whitehead-link-complement Group	20
8 Embeddings of the quotient spaces	25
8.1 Automorphic functions for W vanishing along F_j	26
8.2 An Embedding of $\mathbb{H}^3/S\Gamma_0(1+i)$	30
8.3 An Embedding of \mathbb{H}^3/W	32
8.4 An Embedding of \mathbb{H}^3/W	33

1 Introduction

Figure 1 shows the Whitehead link $L = L_0 \cup L_\infty$ in $S^3 = \mathbb{R}^3 \cup \{\square\}$. The Whitehead-

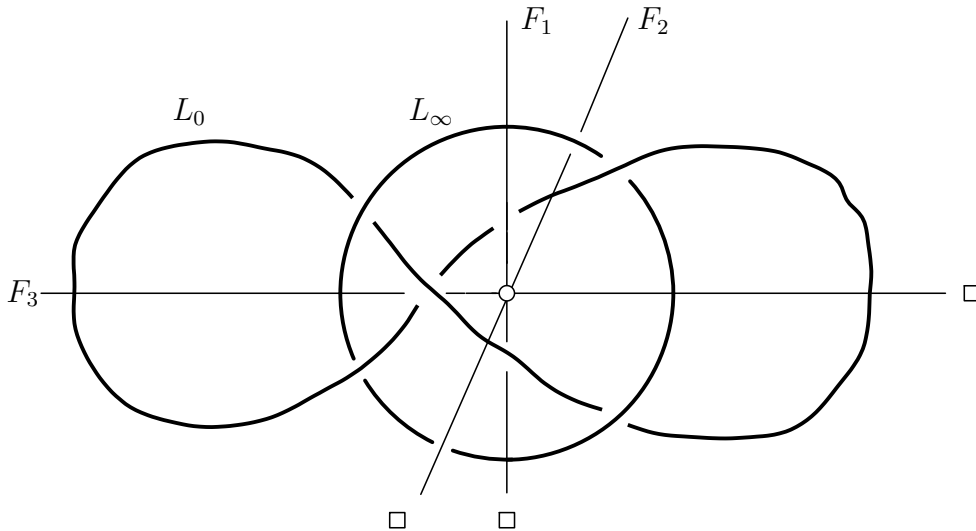

Figure 1: Whitehead link with its symmetry axes

link-complement $S^3 - L$ is known to admit a hyperbolic structure: there is a group W acting properly discontinuously on the 3-dimensional hyperbolic space \mathbb{H}^3 , and there is a homeomorphism

$$h : \mathbb{H}^3/W \xrightarrow{\cong} S^3 - L.$$

No one has ever tried to make the homeomorphism h explicit.

In this paper we construct automorphic functions for W (analytic functions defined in \mathbb{H}^3 which are invariant under W), and express the homeomorphism h in terms of these automorphic functions. Since our embedding of \mathbb{H}^3/W requires many automorphic functions (codimension of the embedding is high), we find several extensions of W , and give their embeddings, which have lower embedding dimensions. In particular, for the extension W' such that $W'/W (\cong (\mathbb{Z}/2\mathbb{Z})^2)$ represents the

group of symmetries (orientation-preserving ambient homotopies) of $L \subset S^3$, we find five automorphic functions, say, h_1, \dots, h_5 , so that the map

$$\mathbb{H}^3 \ni x \longmapsto (h_1(x), \dots, h_5(x)) \in \mathbb{R}^5$$

gives an embedding of \mathbb{H}^3/W' . Its image is explicitly presented as part of an affine algebraic variety.

Our automorphic functions are made from theta functions over the ring $\mathbb{Z}[i]$. Our proofs heavily depends on properties of these theta functions, and on quadratic relations among them established in [M1], [M2] and [MY].

2 A hyperbolic structure on the complement of the Whitehead link

Let \mathbb{H}^3 be the upper half space model

$$\mathbb{H}^3 = \{(z, t) \in \mathbb{C} \times \mathbb{R} \mid t > 0\}$$

of the 3-dimensional real hyperbolic space. The group $GL_2(\mathbb{C})$ and an involution T act on \mathbb{H}^3 as

$$g \cdot (z, t) = \left(\frac{g_{11}\bar{g}_{21}t^2 + (g_{11}z + g_{12})\overline{(g_{21}z + g_{22})}}{|g_{21}|^2t^2 + (g_{21}z + g_{22})\overline{(g_{21}z + g_{22})}}, \frac{|\det(g)|t}{|g_{21}|^2t^2 + (g_{21}z + g_{22})\overline{(g_{21}z + g_{22})}} \right),$$

$$T \cdot (z, t) = (\bar{z}, t),$$

where $g = (g_{jk}) \in GL_2(\mathbb{C})$. Let $GL_2^T(\mathbb{C})$ be the group generated by $GL_2(\mathbb{C})$ and an involution T with relations $T \cdot g = \bar{g} \cdot T$ for $g \in GL_2(\mathbb{C})$.

The Whitehead-link-complement $S^3 - L$ admits a hyperbolic structure (cf. [T][W]): Let W be the discrete subgroup W of $GL_2(\mathbb{C})$ generated by the two elements

$$g_1 = \begin{pmatrix} 1 & i \\ 0 & 1 \end{pmatrix} \quad \text{and} \quad g_2 = \begin{pmatrix} 1 & 0 \\ 1+i & 1 \end{pmatrix}.$$

We have the homeomorphism

$$\mathbb{H}^3/W \xrightarrow{\cong} S^3 - L.$$

We call W the *Whitehead-link-complement group*. A fundamental domain, which will be denoted by FD , for W in \mathbb{H}^3 is given in Figure 2 (cf. [W]); two pyramids are shown. Each face of the pyramids is a mirror of a reflection belonging to $GL_2(\mathbb{Z}[i]) \cdot T$. The faces (together with the corresponding reflections) of the two pyramids and their patching rules are as follows:

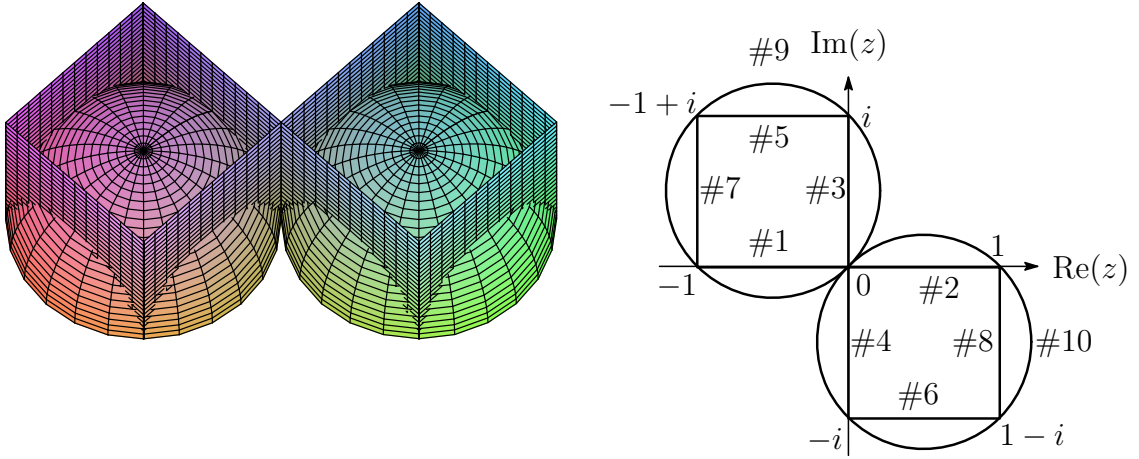

Figure 2: Fundamental domain FD of W in \mathbb{H}^3

The faces of the two pyramids

No.	face	reflection	No.	face	reflection
#1	$\text{Im}(z) = 0,$ $-1 \leq \text{Re}(z) \leq 0,$	$T,$	#2	$\text{Im}(z) = 0,$ $0 \leq \text{Re}(z) \leq 1,$	$T,$
#3	$\text{Re}(z) = 0,$ $0 \leq \text{Im}(z) \leq 1,$	$\begin{pmatrix} -1 & \\ & 1 \end{pmatrix} T,$	#4	$\text{Re}(z) = 0,$ $-1 \leq \text{Im}(z) \leq 0,$	$\begin{pmatrix} -1 & \\ & 1 \end{pmatrix} T,$
#5	$\text{Im}(z) = 1,$ $-1 \leq \text{Re}(z) \leq 1,$	$\begin{pmatrix} 1 & 2i \\ 0 & 1 \end{pmatrix} T,$	#6	$\text{Im}(z) = -1,$ $0 \leq \text{Re}(z) \leq 1,$	$\begin{pmatrix} 1 & -2i \\ 0 & 1 \end{pmatrix} T,$
#7	$\text{Re}(z) = -1,$ $0 \leq \text{Im}(z) \leq 1,$	$\begin{pmatrix} -1 & -2 \\ 0 & 1 \end{pmatrix} T,$	#8	$\text{Re}(z) = 1,$ $-1 \leq \text{Im}(z) \leq 0,$	$\begin{pmatrix} -1 & 2 \\ 0 & 1 \end{pmatrix} T,$
#9	$ z - \frac{-1+i}{2} ^2 + t^2 = \frac{1}{2},$	$\begin{pmatrix} i & 0 \\ 1-i & 1 \end{pmatrix} T,$	#10	$ z - \frac{1-i}{2} ^2 + t^2 = \frac{1}{2},$	$\begin{pmatrix} i & 0 \\ -1+i & 1 \end{pmatrix} T.$

Patching rule

face	element of W	its image	face	element of W	its image
#1	$\begin{pmatrix} 1 & i \\ 0 & 1 \end{pmatrix}$	#5	#2	$\begin{pmatrix} 1 & -i \\ 0 & 1 \end{pmatrix}$	#6
#3	$\begin{pmatrix} 1 & -i \\ 0 & 1 \end{pmatrix}$	#4	#7	$\begin{pmatrix} 1 & 2-i \\ 0 & 1 \end{pmatrix}$	#8
#9	$\begin{pmatrix} 1 & 0 \\ 1+i & 1 \end{pmatrix}$	#10			

The group W has two cusps. They are represented by the vertices of the pyramids:

$$(z, t) = (*, +\infty), \quad (0, 0) \sim (\pm i, 0) \sim (\pm 1, 0) \sim (\mp 1 \pm i, 0).$$

Remark 1 The translation $t_2 := \begin{pmatrix} 1 & 2 \\ 0 & 1 \end{pmatrix}$ is an element of W . Indeed one finds the relation $g_2^{-1}t_2g_1^{-1}g_2^{-1}g_1^{-1}g_2g_1g_2g_1^{-1} = 1$ in $[W]$. We can decide whether a given 2×2 matrix is an element of W by Theorem 5 in §7.3.

3 Discrete subgroups of $GL_2(\mathbb{C})$, especially Λ

We define some discrete subgroups of $GL_2(\mathbb{C})$:

$$\begin{aligned}
\Gamma &= GL_2(\mathbb{Z}[i]), \\
\Gamma_0(1+i) &= \{g = (g_{jk}) \in \Gamma \mid g_{21} \in (1+i)\mathbb{Z}[i]\}, \\
S\Gamma_0(1+i) &= \{g \in \Gamma_0(1+i) \mid \det(g) = \pm 1\}, \\
\Gamma(1+i) &= \{g \in \Gamma \mid g_{11} - 1, g_{12}, g_{21}, g_{22} - 1 \in (1+i)\mathbb{Z}[i]\}, \\
\Gamma(2) &= \{g \in \Gamma \mid g_{11} - 1, g_{12}, g_{21}, g_{22} - 1 \in 2\mathbb{Z}[i]\}, \\
\overline{W} &= TWT = \{\bar{g} \mid g \in W\}, \\
\hat{W} &= W \cap \overline{W}, \\
\check{W} &= \langle W, \overline{W} \rangle.
\end{aligned}$$

Convention: Since we are interested only in the action of these groups on \mathbb{H}^3 , we regard these groups as subgroups of the projectified group $PGL_2(\mathbb{C})$; in other words, every element of the groups represented by a scalar matrix is regarded as the identity. For any subgroup G in Γ , we denote G^T the group generated by G and T in $GL_2^T(\mathbb{C})$.

It is known ([MY]) that the group $\Gamma^T(2)$ is a Coxeter group generated by the eight reflections

$$\begin{aligned}
&T, \quad \begin{pmatrix} -1 & 0 \\ 0 & 1 \end{pmatrix} T, \quad \begin{pmatrix} -1 & -2 \\ 0 & 1 \end{pmatrix} T, \quad \begin{pmatrix} 1 & 2i \\ 0 & 1 \end{pmatrix} T, \\
&\begin{pmatrix} 1 & 0 \\ -2i & 1 \end{pmatrix} T, \quad \begin{pmatrix} -1+2i & -2 \\ 2 & 1+2i \end{pmatrix} T, \quad \begin{pmatrix} 1+2i & 2i \\ -2i & 1-2i \end{pmatrix} T, \quad \begin{pmatrix} -1 & 0 \\ 2 & 1 \end{pmatrix} T.
\end{aligned}$$

The mirrors of the reflections are four walls $\text{Im}(z) = 0$, $\text{Re}(z) = 0$, $\text{Re}(z) = -1$, $\text{Im}(z) = 1$, and four northern hemispheres with radius $\frac{1}{2}$ and centers $\frac{i}{2}$, $\frac{-1}{2} + i$, $-1 + \frac{i}{2}$, $\frac{-1}{2}$, respectively, see Figure 3. Note that the Weyl chamber bounded by these eight mirrors is an (ideal) octahedron in the hyperbolic space \mathbb{H}^3 .

The group $\Gamma^T(2)$ is well-studied in [MY]. To relate $\Gamma^T(2)$ with the Whitehead-link-complement group W , we consider the smallest group which contains both $\Gamma^T(2)$ and W :

$$\Lambda = \langle \Gamma^T(2), W \rangle.$$

Lemma 1 1. $\Gamma^T(2)$ is a normal subgroup of Λ , and $\Lambda/\Gamma^T(2)$ is isomorphic to the dihedral group of order eight.

2. $[\Lambda, W] = 8$, W is not a normal subgroup of Λ : $TWT = \overline{W}$.

Proof. 1. We extend the reflection group $\Gamma^T(2)$ by adding the reflection g_1T with mirror $\text{Im}z = 1/2$, and the 2-fold rotation with axis the geodesic arc joining the points $(z, t) = (0, 0)$ and $(-1 + i, 0)$, which is given by

$$R = \begin{pmatrix} i & 0 \\ 1 - i & -i \end{pmatrix}.$$

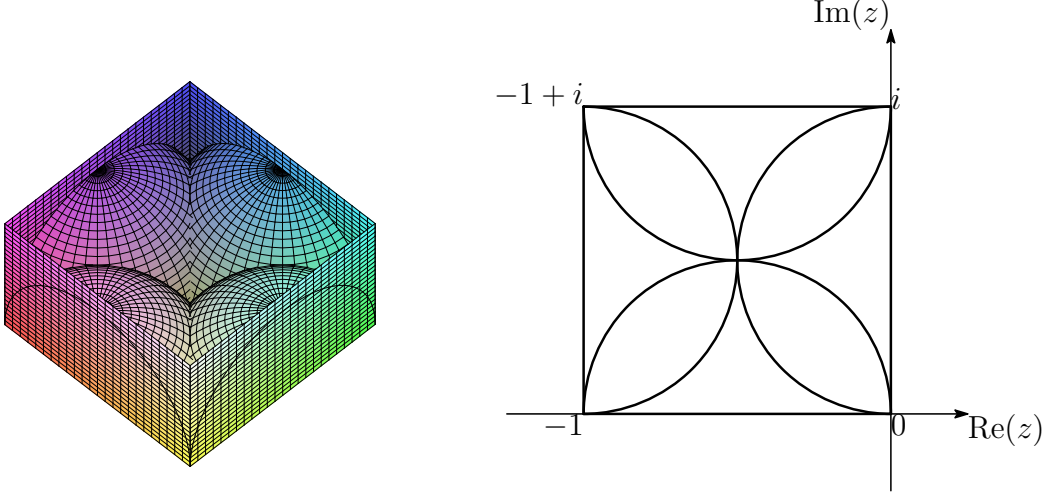

Figure 3: Weyl chamber of $\Gamma^T(2)$

These reflection and rotation preserve the Weyl chamber above, and generate a group isomorphic to the dihedral group of order eight. Since we have

$$\begin{pmatrix} -1 & 0 \\ 2 & 1 \end{pmatrix}, \quad \begin{pmatrix} 1 & 0 \\ 2 & -1 \end{pmatrix} \in \Gamma^T(2)$$

and

$$\begin{pmatrix} 1 & 0 \\ 2 & -1 \end{pmatrix} \begin{pmatrix} i & 0 \\ 1-i & -i \end{pmatrix} \begin{pmatrix} -1 & 0 \\ 2 & 1 \end{pmatrix} = -i \begin{pmatrix} 1 & 0 \\ -1-i & 1 \end{pmatrix} = g_2^{-1}$$

this extended group coincides with Λ .

2. By comparing the Weyl chamber of $\Gamma^T(2)$ with the fundamental domain FD of W , we see that W has the same co-volume with $\Gamma^T(2)$. Thus $[\Lambda, W] = 8$. q.e.d.

From the proof of this Lemma, we have

Corollary 1 *The domain bounded by the four walls*

$$a : \text{Im}(z) = 0, \quad b : \text{Re}(z) = 0, \quad c : \text{Im}(z) = \frac{1}{2}, \quad d : \text{Re}(z) = -\frac{1}{2}$$

and the big hemisphere #9 in §2 is a fundamental domain of Λ , see Figure 4. The hemisphere part is folded by the rotation R above.

We use this fundamental domain in §5.3.

Lemma 2 *We have $\Lambda = S\Gamma_0^T(1+i)$ and $[S\Gamma_0^T(1+i), W] = 4$.*

Proof. It is clear that $\Lambda \subset S\Gamma_0^T(1+i)$. Since

$$[\Gamma_0^T(1+i), \Gamma^T(2)] = 16 \quad \text{and} \quad [\Gamma_0^T(1+i), S\Gamma_0^T(1+i)] = 2,$$

we have $\Lambda = S\Gamma_0^T(1+i)$.

q.e.d.

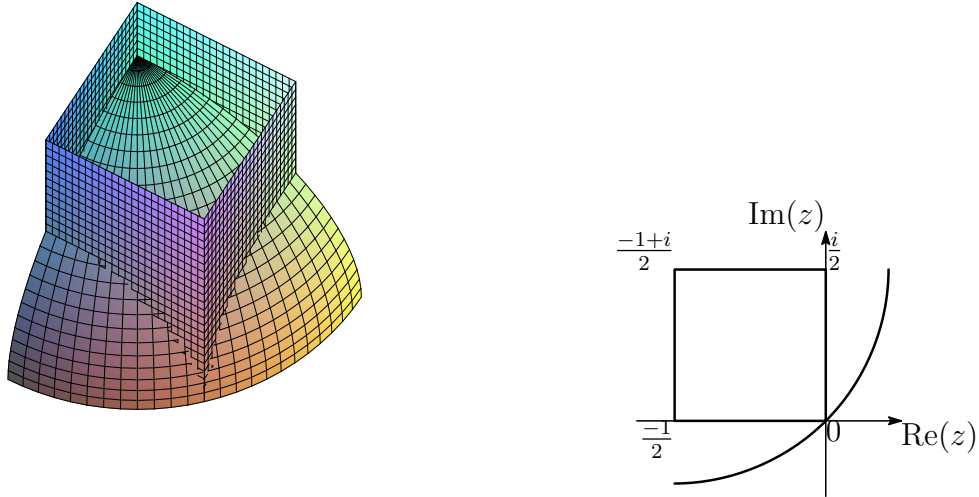

Figure 4: Fundamental domain of Λ

So far we defined many subgroups of $\Gamma^T = GL_2^T(\mathbb{Z}[i])$; their inclusion relation can be depicted as follows:

$$\begin{array}{ccc}
 & & \Gamma_0^T(1+i) \\
 & & | \\
 \Gamma^T(1+i) & \diagdown & \Lambda = S\Gamma_0^T(1+i) \\
 & \diagup & | \\
 S\Gamma^T(1+i) & & S\Gamma_0(1+i) \\
 & & | \\
 & & \check{W} = \langle W, \overline{W} \rangle \\
 & & \swarrow \quad \searrow \\
 & & W \quad \quad \overline{W} \\
 & & \searrow \quad \swarrow \\
 & & \hat{W} = W \cap \overline{W} \\
 & & | \\
 & & \Gamma^T(2) \\
 & & | \\
 & & \Gamma(2)
 \end{array}$$

When two groups are connected by a segment, the one below is a subgroup of the one above of index 2. More explanation about these groups will be given in §7.2.

4 Symmetry of the Whitehead link

In this section, we study the symmetries of the Whitehead link, and express each symmetry as an extension of the group W .

4.1 Symmetries of L

Orientation preserving homeomorphisms of S^3 keeping L fixed form a group isomorphic to $(\mathbb{Z}/2\mathbb{Z})^2$; the group consists of π -rotations with axes F_1, F_2 and F_3 , and the identity. Here the axes are defined in Figure 1; F_1 (resp. F_2) meet L_∞ (resp. L_0) at two points, and F_3 meets L_∞ at two points and L_0 at two points. There is also a reflection (an orientation reversing homeomorphism) of S^3 keeping a mirror (containing L) pointwise fixed.

Recall that there is a homeomorphism $S^3 - L \cong \mathbb{H}^3/W$ where the strings L_0 and L_∞ correspond to the cusps of W represented by

$$0 := (0, 0), \quad \text{and} \quad \infty := (*, +\infty) \in \partial\mathbb{H}^3,$$

respectively. Under this identification, we show

Proposition 1 *The three π -rotations with axes F_1, F_2 and F_3 , and the reflection can be represented by the transformations*

$$z \mapsto -z + 1, \quad z \mapsto z + 1, \quad z \mapsto -z, \quad \text{and} \quad z \mapsto \bar{z},$$

respectively, of \mathbb{H}^3 modulo W .

This assertion will be clear as soon as we study the fixed points of these transformations in the next subsection. Note that the three rotations modulo W (and the identity) form a group isomorphic to $(\mathbb{Z}/2\mathbb{Z})^2$, since $[z \mapsto z + 2] \in W$ (see Remark 1).

We make some convention. The symbols \square and \circ stand for the points in the W -orbits of

$$\square = \left(\frac{-1+i}{2}, \frac{1}{\sqrt{2}} \right), \quad \text{and} \quad \circ = \left(\frac{i}{2}, \frac{1}{2} \right) \in \mathbb{H}^3,$$

respectively. Let π be the projection

$$\pi : \mathbb{H}^3 \ni (z, t) \mapsto z \in \mathbb{C} : z\text{-plane.}$$

In the figures on the z -plane, a thick segment stands for a geodesic curve (in the upper half space \mathbb{H}^3) on the hemispheres with center $(\pm\frac{1-i}{2}, 0)$ and radius $\frac{1}{\sqrt{2}}$ (the big hemispheres #9 and #10 in §2); its image under π is the given segment.

The eight geodesics in the fundamental domain FD shown in Figure 2, given as the intersections of walls

$$\#1 \cap \#9, \#3 \cap \#9, \#5 \cap \#9, \#7 \cap \#9, \#2 \cap \#10, \#4 \cap \#10, \#6 \cap \#10, \#8 \cap \#10,$$

are identified modulo W as is seen in Figure 5. This identification will be used freely later.

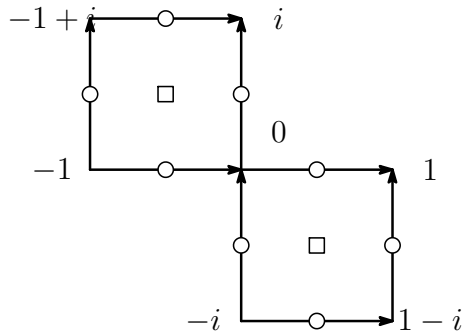

Figure 5: Identification of eight geodesics in FD

4.2 Fixed loci

We study the fixed points of the transformations in Proposition 1 in \mathbb{H}^3/W . Recall that the translations $[z \mapsto z + i]$ and $[z \mapsto z + 2]$ belong to W .

1. The transformation of \mathbb{H}^3/W represented by $[z \mapsto -z + 1]$ fixes pointwise the following geodesics in FD :

$$z = -\frac{1}{2}, \quad z = \frac{1}{2}, \quad z = \frac{1-i}{2}, \quad z = \frac{-1+i}{2}.$$

In fact, for example, we have

$$\begin{aligned} -\frac{1}{2} &\longrightarrow -\left(-\frac{1}{2}\right) + 1 = -\frac{1}{2} + 2 \equiv -\frac{1}{2} \pmod{2}, \\ \frac{1-i}{2} &\longrightarrow -\frac{1-i}{2} + 1 = \frac{1-i}{2} + i \equiv \frac{1-i}{2} \pmod{i}. \end{aligned}$$

Thus the set of fixed points consists of two geodesics both starting and ending at $\infty \in \partial\mathbb{H}^3$, and passing through \square and \circ , respectively. These can be easily understood by the diagram:

$$\infty \text{---} \square \text{---} \infty, \quad \infty \text{---} \circ \text{---} \infty.$$

This implies that this transformation represents the rotation with axis F_1 .

2. The transformation $[z \mapsto z + 1]$ fixes pointwise the following geodesics in FD :

geodesic joining 0 and $(i, 0)$ through \circ ,

geodesic joining $(i, 0)$ and $(-1, 0)$ through \square .

In fact, the former can be seen by the translation of the z -plane by i , and the identification of the eight geodesics shown in Figure 5; and the latter by the same translation and the transformation patching the big hemispheres #9 and #10 appeared in §2. Thus the set of fixed points consists of two geodesics both starting and ending at $0 \in \partial\mathbb{H}^3$, and passing through \square and \circ , respectively. These can be easily understood by the diagram:

$$0 \text{---} \square \text{---} 0, \quad 0 \text{---} \circ \text{---} 0.$$

This implies that this transformation represents the rotation with axis F_2 .

3. The transformation $[z \mapsto -z]$ fixes pointwise the following geodesics in FD :

geodesic joining 0 and $(-1 + i, 0)$ through \square ,

$$z = 0, \quad z = -1, \quad z = -1 + \frac{i}{2}, \quad z = \frac{i}{2}.$$

One can check these in the same way as the above two cases. These can be visualized as

$$0 \text{---} \square \text{---} 0, \quad 0 \text{---} \infty, \quad \infty \text{---} \circ \text{---} \infty, \quad \infty \text{---} 0.$$

This implies that this transformation represents the rotation with axis F_3 .

4. The transformation $[z \mapsto \bar{z}]$ fixes pointwise the walls $\text{Im}(z) = 0, \pm 1/2$. This represents a reflection with a mirror containing L . We will explain more in §5.3.

The fixed loci in FD , as well as in \mathbb{H}^3/W , of the rotations $[z \mapsto -z + 1]$, $[z \mapsto z + 1]$ and $[z \mapsto -z]$ are also called the axes F_1, F_2 and F_3 ; they are depicted in FD as in Figure 6. A bullet \bullet stands for a vertical line: the inverse image of the point under π .

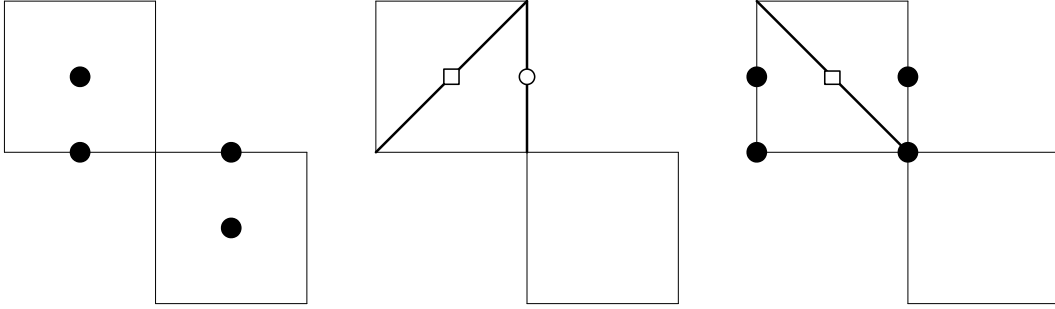

Figure 6: The fixed loci of $[z \mapsto -z + 1]$, $[z \mapsto z + 1]$, $[z \mapsto -z]$

5 Orbit spaces under \check{W} , $ST_0(1+i)$ and Λ

Note that $W \subset \check{W} \subset ST_0(1+i) \subset \Lambda$,

$$|\check{W}/W| = |ST_0(1+i)/\check{W}| = |\Lambda/ST_0(1+i)| = 2, \quad ST_0(1+i)/W \cong (\mathbb{Z}/2\mathbb{Z})^2,$$

and that

$$[z \mapsto -z + 1] \in \check{W} - W, \quad [z \mapsto -z] \in ST_0(1+i) - \check{W}, \quad [z \mapsto \bar{z}] \in \Lambda - ST_0(1+i).$$

By quotienting out the symmetry of the Whitehead link, we will see an essence of the Whitehead link. In fact, though the Whitehead link has at least five crossings, we will see that the quotient space has only one crossing; of course the ambient space necessarily has orbifold singularities.

5.1 The orbifold \mathbb{H}^3/\check{W}

Figure 7(left) shows a fundamental domain for \check{W} in FD ; every wall has a counterpart to be identified with (under the order-2-rotations around the geodesics $z = \pm \frac{1-i}{2}$, together with the patching rules of the walls tabulated in §2).

In the figure, a very thick segment stands for a vertical plane: the inverse image of the segment under π .

The quotient of S^3 , where L lives, by the π -rotation around the axis F_1 is again a 3-sphere but with orbifold-singularities of index 2 along a curve; in Figure 7(right), this curve is labeled by F_1 and the numeral 2 is attached.

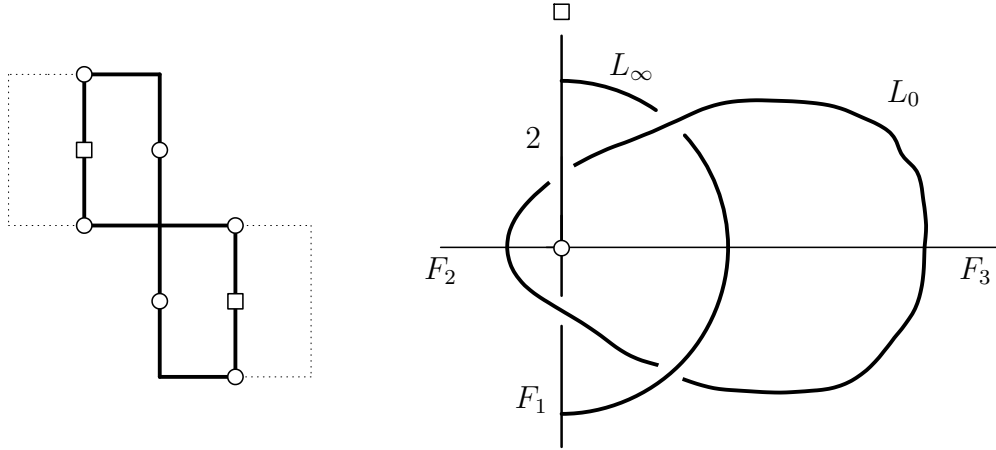

Figure 7: A fundamental domain for \check{W} and the orbifold \mathbb{H}^3/\check{W}

5.2 The orbifold $\mathbb{H}^3/ST_0(1+i)$

Figure 8(left) shows a fundamental domain for $ST_0(1+i)$ in FD bounded by the four walls and the rectangle (part of the hemisphere #9 cut out by the four walls). Every wall has a counterpart to be identified with (under the order-2-rotations around the geodesics $z = \frac{i}{2}, \frac{-1+i}{2}$, together with the displacement $[z \mapsto z + i]$). The rectangle is divided into two squares; the upper square is folded (identified) by the rotation centered along the geodesic joining \square and $(i, 0)$, and the lower one is folded by the rotation centered along the geodesics joining \square and $0 = (0, 0)$.

The quotient of S^3 , where L lives, by the π -rotations around the axes F_1, F_2 and F_3 – this is equivalent to the quotient of the orbifold \mathbb{H}^3/\check{W} obtained in the previous subsection by the π -rotation around the horizontal axis shown in Figure 7(right) – is again a 3-sphere but with orbifold-singularities of index 2 along three curves; in Figure 8(right), these curves are labeled by F_1, F_2 and F_3 , and the numeral 2 is attached to each of these.

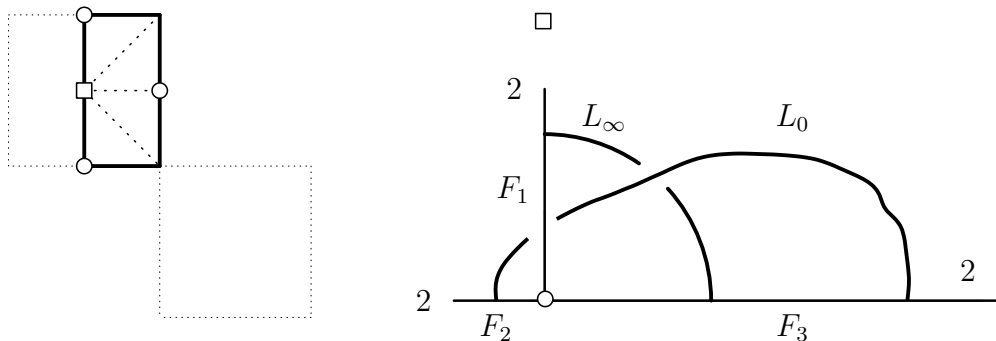

Figure 8: A fundamental domain for $ST_0(1+i)$ and the orbifold $\mathbb{H}^3/ST_0(1+i)$

5.3 The orbifold \mathbb{H}^3/Λ

Figure 10(left) shows a fundamental domain for Λ in FD bounded by the four walls a, b, c and d defined in Corollary 1, and the square (part of the hemisphere #9 cut

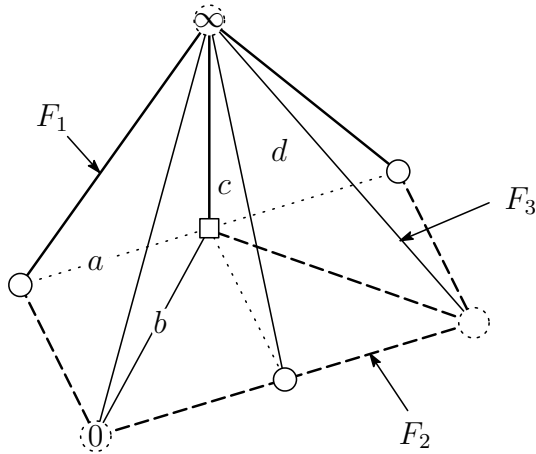

Figure 9: A better picture of the fundamental domain for $ST_0(1+i)$

out by the four walls). Every wall has no counterpart to be identified with. The square is folded (identified) by the rotation centered with the geodesic joining \square and $0 = (0,0)$. Thus the orbifold \mathbb{H}^3/Λ must be a 3-ball bounded by the 2-sphere divided by four (triangular) walls, which are shown in Figure 10(right).

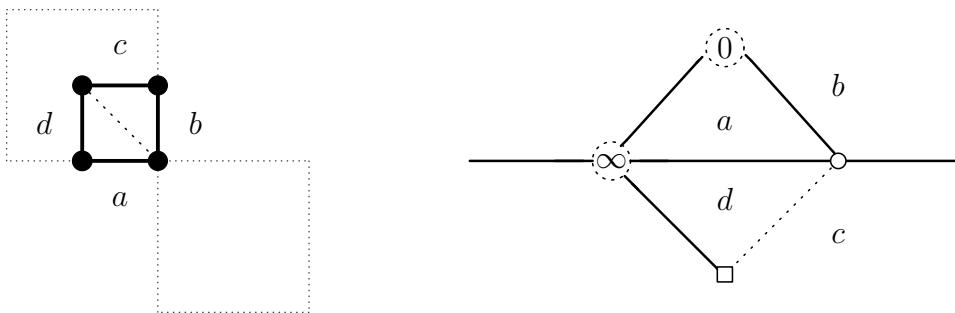

Figure 10: A fundamental domain for Λ and the boundary of \mathbb{H}^3/Λ

On the other hand the orbifold \mathbb{H}^3/Λ should be equivalent to the quotient of the orbifold $\mathbb{H}^3/ST_0(1+i)$ obtained in the previous subsection by the reflection represented by $T : z \mapsto \bar{z}$. The mirror of the reflection in the orbifold $\mathbb{H}^3/ST_0(1+i)$ is shown in 11 as the union of four *triangles*, they are labeled by a, b, c and d for the obvious reason.

6 Theta functions

In §6.1,6.2, 6.3, we introduce some results for theta functions defined on the Hermitian symmetric domain \mathbb{D} , and restrict them on \mathbb{H}^3 embedded in \mathbb{D} ; refer to [F],[M1], [M2] and [MY]. In §6.4, the final subsection, we give an embedding of \mathbb{H}^3/Λ .

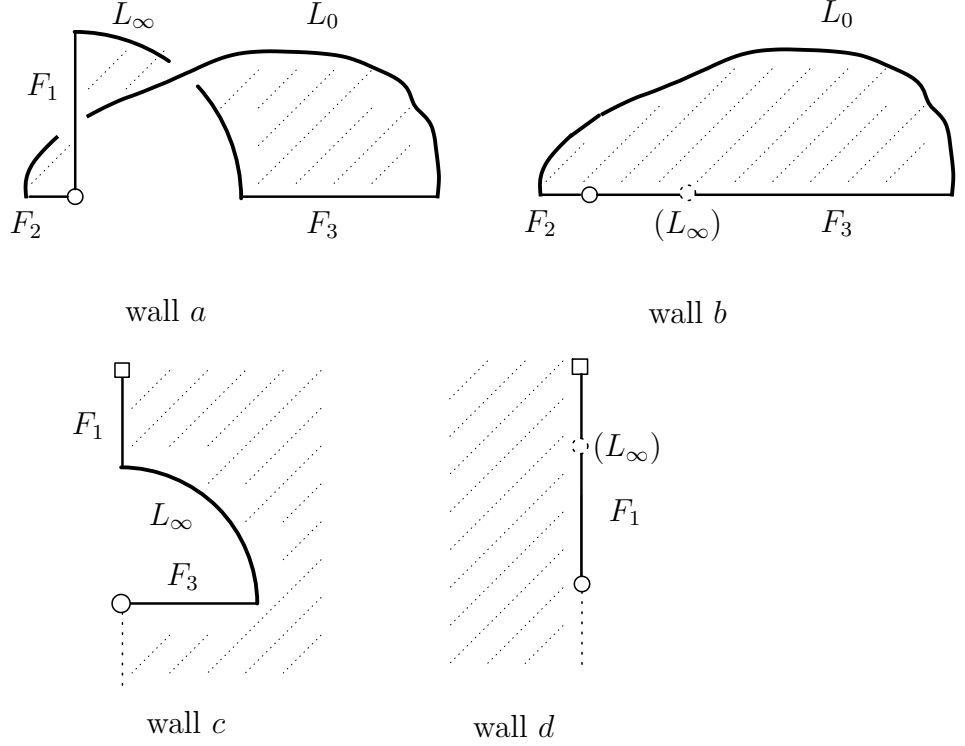

Figure 11: The mirror of the reflection in the orbifold $\mathbb{H}^3/ST_0(1+i)$ is shown as the union of four parts

6.1 Theta functions on \mathbb{D}

The symmetric domain \mathbb{D} of type $I_{2,2}$ is defined as

$$\mathbb{D} = \left\{ \tau \in M_{2,2}(\mathbb{C}) \mid \frac{\tau - \tau^*}{2i} \text{ is positive definite} \right\}.$$

The group

$$U_{2,2}(\mathbb{C}) = \left\{ g \in GL_4(\mathbb{C}) \mid gJg^* = J = \begin{pmatrix} O & -I_2 \\ I_2 & O \end{pmatrix} \right\}$$

and an involution T act on \mathbb{D} as

$$g \cdot \tau = (g_{11}\tau + g_{12})(g_{21}\tau + g_{22})^{-1}, \quad T \cdot \tau = {}^t\tau,$$

where $g = (g_{jk}) \in U_{2,2}(\mathbb{C})$, and g_{jk} are 2×2 matrices.

Theta functions $\Theta \begin{pmatrix} a \\ b \end{pmatrix}(\tau)$ on \mathbb{D} are defined as

$$\Theta \begin{pmatrix} a \\ b \end{pmatrix}(\tau) = \sum_{n \in \mathbb{Z}[i]^2} \mathbf{e}[(n+a)\tau(n+a)^* + 2\text{Re}(nb^*)],$$

where $\tau \in \mathbb{D}$, $a, b \in \mathbb{Q}[i]^2$ and $\mathbf{e}[x] = \exp[\pi ix]$. By definition, we have the following theta-transformation-formulas.

Fact 1 1. If $b \in \frac{1}{1+i}\mathbb{Z}[i]^2$, then $\Theta \begin{pmatrix} a \\ ib \end{pmatrix}(\tau) = \Theta \begin{pmatrix} a \\ b \end{pmatrix}(\tau)$.

If $b \in \frac{1}{2}\mathbb{Z}[i]^2$, then $\Theta \begin{pmatrix} a \\ -b \end{pmatrix}(\tau) = \Theta \begin{pmatrix} a \\ b \end{pmatrix}(\tau)$.

2. For $k \in \mathbb{Z}$ and $m, n \in \mathbb{Z}[i]^2$, we have

$$\begin{aligned}\Theta\left(\begin{smallmatrix} i^k a \\ i^k b \end{smallmatrix}\right)(\tau) &= \Theta\left(\begin{smallmatrix} a \\ b \end{smallmatrix}\right)(\tau), \\ \Theta\left(\begin{smallmatrix} a+m \\ b+n \end{smallmatrix}\right)(\tau) &= \mathbf{e}[-2\operatorname{Re}(mb^*)]\Theta\left(\begin{smallmatrix} a \\ b \end{smallmatrix}\right)(\tau).\end{aligned}$$

3. We have

$$\begin{aligned}\Theta\left(\begin{smallmatrix} a \\ b \end{smallmatrix}\right)(g\tau g^*) &= \Theta\left(\begin{smallmatrix} ag \\ b(g^*)^{-1} \end{smallmatrix}\right)(\tau) \quad \text{for } g \in \Gamma, \\ \Theta\left(\begin{smallmatrix} a \\ b \end{smallmatrix}\right)(T \cdot \tau) &= \Theta\left(\begin{smallmatrix} \bar{a} \\ \bar{b} \end{smallmatrix}\right)(\tau).\end{aligned}$$

It is shown in [M2] that theta functions $\Theta\left(\begin{smallmatrix} a \\ b \end{smallmatrix}\right)(\tau)$ satisfy the following quadratic relations.

Proposition 2 *We have*

$$\begin{aligned}&4\Theta\left(\begin{smallmatrix} a+c \\ b+d \end{smallmatrix}\right)(\tau)\Theta\left(\begin{smallmatrix} a-c \\ b-d \end{smallmatrix}\right)(\tau) \\ &= \sum_{e, f \in \frac{1+i}{2}\mathbb{Z}[i]^2/\mathbb{Z}[i]^2} \mathbf{e}[2\operatorname{Re}((1+i)(b+d)e^*)]\Theta\left(\begin{smallmatrix} e+(1+i)a \\ f+(1+i)b \end{smallmatrix}\right)(\tau)\Theta\left(\begin{smallmatrix} e+(1+i)c \\ f+(1+i)d \end{smallmatrix}\right)(\tau).\end{aligned}$$

Especially,

$$4\Theta\left(\begin{smallmatrix} a \\ b \end{smallmatrix}\right)(\tau)^2 = \sum_{e, f \in \frac{1+i}{2}\mathbb{Z}[i]^2/\mathbb{Z}[i]^2} \mathbf{e}[2\operatorname{Re}((1+i)be^*)]\Theta\left(\begin{smallmatrix} e+(1+i)a \\ f+(1+i)b \end{smallmatrix}\right)(\tau)\Theta\left(\begin{smallmatrix} e \\ f \end{smallmatrix}\right)(\tau).$$

6.2 Embedding of \mathbb{H}^3 into \mathbb{D} and the pull-back of the theta functions

We embed \mathbb{H}^3 into \mathbb{D} by

$$j : \mathbb{H}^3 \ni (z, t) \mapsto \frac{i}{t} \begin{pmatrix} t^2 + |z|^2 & z \\ \bar{z} & 1 \end{pmatrix} \in \mathbb{D};$$

accordingly, we define the homomorphism

$$j : GL_2(\mathbb{C}) \ni g \mapsto \begin{pmatrix} g/|\det(g)| & O \\ O & (g^*/|\det(g)|)^{-1} \end{pmatrix} \in U_{2,2}(\mathbb{C}),$$

which we denote by the same symbol j , sorry. They satisfy

$$\begin{aligned}j(g \cdot (z, t)) &= j(g) \cdot j(z, t) \quad \text{for any } g \in GL_2(\mathbb{C}), \\ j(T \cdot (z, t)) &= T \cdot j(z, t).\end{aligned}$$

We denote the pull back of $\Theta\left(\begin{smallmatrix} a \\ b \end{smallmatrix}\right)(\tau)$ under the embedding $j : \mathbb{H}^3 \rightarrow \mathbb{D}$ by $\Theta\left(\begin{smallmatrix} a \\ b \end{smallmatrix}\right)(z, t)$. The following is shown in [M1] and [MY].

- Fact 2**
1. For $a, b \in \frac{1}{2}\mathbb{Z}[i]^2$, each $\Theta\binom{a}{b}(z, t)$ is real valued. If $\operatorname{Re}(ab^*) + \operatorname{Im}(ab^*) \notin \frac{1}{2}\mathbb{Z}[i]$ then $\Theta\binom{a}{b}(z, t)$ is identically zero.
 2. If $b = (0, 0)$ then $\Theta\binom{a}{b}(z, t)$ is non-negative.
 3. For $a, b \in \frac{1}{1+i}\mathbb{Z}[i]^2$, each $\Theta\binom{a}{b}(z, t)$ is invariant under the action of $\Gamma^T(2)$.
 4. The function $\Theta = \Theta\binom{00}{00}(z, t)$ is positive and invariant under the action of Γ^T .

6.3 Automorphic functions for $\Gamma^T(2)$ and an embedding of $\mathbb{H}^3/\Gamma^T(2)$

Set

$$\Theta\begin{bmatrix} p \\ q \end{bmatrix} = \Theta\begin{bmatrix} p \\ q \end{bmatrix}(z, t) = \Theta\left(\frac{p}{q}\right)(z, t), \quad p, q \in \mathbb{Z}[i]^2$$

and

$$x_0 = \Theta, \quad x_1 = \Theta\begin{bmatrix} 1+i, 1+i \\ 1+i, 1+i \end{bmatrix}, \quad x_2 = \Theta\begin{bmatrix} 1+i, 0 \\ 0, 1+i \end{bmatrix}, \quad x_3 = \Theta\begin{bmatrix} 0, 1+i \\ 1+i, 0 \end{bmatrix}.$$

One of the main results in [MY] is

Theorem 1 *The map*

$$\mathbb{H}^3 \ni (z, t) \mapsto \frac{1}{x_0}(x_1, x_2, x_3) \in \mathbb{R}^3$$

induces an isomorphism between $\mathbb{H}^3/\Gamma^T(2)$ and the octahedron

$$\text{Oct} = \{(t_1, t_2, t_3) \in \mathbb{R}^3 \mid |t_1| + |t_2| + |t_3| \leq 1\}$$

minus the six vertices $(\pm 1, 0, 0), (0, \pm 1, 0), (0, 0, \pm 1)$.

There are essentially ten non-zero $\Theta\binom{a}{b}(\tau)$ for $a, b \in \frac{1}{2}\mathbb{Z}[i]^2$. Their restrictions on \mathbb{H}^3 are expressed in terms of x_0, \dots, x_3 in [MY]; we cite these expression as

Fact 3

$$\begin{aligned} \Theta\begin{bmatrix} 1+i, 1+i \\ 0, 0 \end{bmatrix}^2 &= \Theta\begin{bmatrix} 0, 0 \\ 1+i, 1+i \end{bmatrix}^2 = \frac{1}{2}(x_0^2 + x_1^2 - x_2^2 - x_3^2), \\ \Theta\begin{bmatrix} 1+i, 0 \\ 0, 0 \end{bmatrix}^2 &= \Theta\begin{bmatrix} 0, 0 \\ 0, 1+i \end{bmatrix}^2 = \frac{1}{2}(x_0^2 - x_1^2 + x_2^2 - x_3^2), \\ \Theta\begin{bmatrix} 0, 1+i \\ 0, 0 \end{bmatrix}^2 &= \Theta\begin{bmatrix} 0, 0 \\ 1+i, 0 \end{bmatrix}^2 = \frac{1}{2}(x_0^2 - x_1^2 - x_2^2 + x_3^2). \end{aligned}$$

6.4 Automorphic functions for Λ and an embedding of \mathbb{H}^3/Λ

Once an embedding of $\mathbb{H}^3/\Gamma^T(2)$ is obtained, in terms of x_j , for a *supergroup* Λ of $\Gamma^T(2)$, an embedding of \mathbb{H}^3/Λ can be obtained by polynomials of the x_j 's invariant under the finite group $\Lambda/\Gamma^T(2)$; this is a routine process. Since we have $\Lambda = \langle \Gamma^T(2), g_1, g_2 \rangle$, we study the actions of the generators g_1 and g_2 of the Whitehead-link-complement group W on the theta functions $\Theta \begin{bmatrix} a \\ b \end{bmatrix}$ for $a, b \in (1+i)\mathbb{Z}[i]$. The theta-transformation-formulas (Fact 1) leads to the following.

Proposition 3 *The generators g_1 and g_2 induce linear transformations of x_1, x_2 and x_3 :*

$$\begin{pmatrix} x_1 \\ x_2 \\ x_3 \end{pmatrix} \cdot g_1 = \begin{pmatrix} & -1 & \\ -1 & & \\ & & 1 \end{pmatrix} \begin{pmatrix} x_1 \\ x_2 \\ x_3 \end{pmatrix}, \quad \begin{pmatrix} x_1 \\ x_2 \\ x_3 \end{pmatrix} \cdot g_2 = \begin{pmatrix} -1 & & \\ & 1 & \\ & & -1 \end{pmatrix} \begin{pmatrix} x_1 \\ x_2 \\ x_3 \end{pmatrix}.$$

Theorem 2 *The functions $x_1^2 + x_2^2, x_1^2 x_2^2, x_3^2$ and $x_1 x_2 x_3$ are invariant under the action of Λ . The map*

$$\lambda : \mathbb{H}^3 \ni (z, t) \longmapsto (\lambda_1, \lambda_2, \lambda_3, \lambda_4) = (\xi_1^2 + \xi_2^2, \xi_1^2 \xi_2^2, \xi_3^2, \xi_1 \xi_2 \xi_3) \in \mathbb{R}^4,$$

where $\xi_j = x_j/x_0$, induces an embedding of \mathbb{H}^3/Λ into the subdomain of the variety $\lambda_2 \lambda_3 = \lambda_4^2$ (homeomorphic to a 3-ball with two holes) bounded by the four triangular faces, which are the images (under $\mathbb{H}^3/\Gamma^T(2) \ni x \mapsto \lambda \in \mathbb{H}^3/\Lambda$) of

$$a : x_1 - x_2 + x_3 = x_0, \quad b : x_1 + x_2 + x_3 = x_0, \quad c : x_1 - x_2 = 0, \quad d : x_1 + x_2 = 0.$$

Proof. Since $\Lambda = \langle \Gamma^T(2), g_1, g_2 \rangle$, we have the first half of this theorem. The definition of the group Λ in §3, the fundamental domain of Λ in §5.3, and Theorem 1 lead to the latter half.

Remark 2 (1) *The two matrices appeared in Proposition 3 generate a subgroup of $GL_3(\mathbb{Z})$ isomorphic to the dihedral group of order eight.*

(2) *By Proposition 3, we have*

$$\begin{pmatrix} x_2 - x_1 \\ x_2 + x_1 \end{pmatrix} \cdot g_1 = \begin{pmatrix} 1 & \\ & -1 \end{pmatrix} \begin{pmatrix} x_2 - x_1 \\ x_2 + x_1 \end{pmatrix}, \quad \begin{pmatrix} x_2 - x_1 \\ x_2 + x_1 \end{pmatrix} \cdot g_2 = \begin{pmatrix} & 1 \\ 1 & \end{pmatrix} \begin{pmatrix} x_2 - x_1 \\ x_2 + x_1 \end{pmatrix}.$$

The group generated by these matrices is isomorphic to the dihedral group of order eight.

Proposition 4 *The functions*

$$\Theta \begin{bmatrix} 0, 1+i \\ 0, 0 \end{bmatrix}, \quad \Theta \begin{bmatrix} 1+i, 1+i \\ 0, 0 \end{bmatrix} + \Theta \begin{bmatrix} 1+i, 0 \\ 0, 0 \end{bmatrix}, \quad \text{and} \quad \Theta \begin{bmatrix} 1+i, 1+i \\ 0, 0 \end{bmatrix} \Theta \begin{bmatrix} 1+i, 0 \\ 0, 0 \end{bmatrix}$$

are invariant under the action of Λ .

Proof. Since $\Theta \begin{bmatrix} 1+i, 1+i \\ 0, 0 \end{bmatrix}$, $\Theta \begin{bmatrix} 1+i, 0 \\ 0, 0 \end{bmatrix}$ and $\Theta \begin{bmatrix} 0, 1+i \\ 0, 0 \end{bmatrix}$ are non-negative by Fact 2, Fact 3 implies the identities of real valued functions:

$$\begin{aligned} \Theta \begin{bmatrix} 0, 1+i \\ 0, 0 \end{bmatrix} &= \frac{1}{\sqrt{2}} \sqrt{x_0^2 - x_1^2 - x_2^2 + x_3^2}, \\ \Theta \begin{bmatrix} 1+i, 1+i \\ 0, 0 \end{bmatrix} + \Theta \begin{bmatrix} 1+i, 0 \\ 0, 0 \end{bmatrix} &= \frac{1}{\sqrt{2}} \left(\sqrt{x_0^2 + x_1^2 - x_2^2 - x_3^2} + \sqrt{x_0^2 - x_1^2 + x_2^2 - x_3^2} \right), \\ \Theta \begin{bmatrix} 1+i, 1+i \\ 0, 0 \end{bmatrix} \Theta \begin{bmatrix} 1+i, 0 \\ 0, 0 \end{bmatrix} &= \frac{1}{2} \sqrt{(x_0^2 + x_1^2 - x_2^2 - x_3^2)(x_0^2 - x_1^2 + x_2^2 - x_3^2)}. \end{aligned}$$

They are invariant under the action of Λ by Proposition 3.

q.e.d.

7 Automorphic functions for W

We would like to give an explicit embedding of \mathbb{H}^3/W . Though we already found an embedding of \mathbb{H}^3/Λ , since W is a *subgroup* of Λ , we must find new functions invariant under the action of W , which are not invariant under Λ . In this section, we construct such automorphic functions Φ_1, Φ_2 and Φ_3 for W by utilizing theta functions with characteristics in $\frac{1}{2}\mathbb{Z}[i]$. We define these functions and show their fundamental properties in §7.1. We show in §7.2 that the groups $S\Gamma_0(1+i)$, $\check{W} = \langle W, \overline{W} \rangle$ and W can be regarded as isotropy subgroups of some of these functions. An arithmetical characterization of the Whitehead-link-complement group W is given in §7.3.

7.1 Fundamental properties of Φ_1, Φ_2 and Φ_3

Set

$$y_1 = \Theta \begin{bmatrix} 0, 1 \\ 1+i, 0 \end{bmatrix}, \quad y_2 = \Theta \begin{bmatrix} 1+i, 1 \\ 1+i, 0 \end{bmatrix}, \quad z_1 = \Theta \begin{bmatrix} 0, 1 \\ 1, 0 \end{bmatrix}, \quad z_2 = \Theta \begin{bmatrix} 1+i, 1 \\ 1, 1+i \end{bmatrix}.$$

We define functions Φ_1, Φ_2 and Φ_3 as

$$\Phi_1 = x_3 z_1 z_2, \quad \Phi_2 = (x_2 - x_1) y_1 + (x_2 + x_1) y_2, \quad \Phi_3 = (x_1^2 - x_2^2) y_1 y_2.$$

Theorem 3 *The functions Φ_1, Φ_2 and Φ_3 are invariant under the action of W . Only the signs of them change by the action of $g = I_2 + 2 \begin{pmatrix} p & q \\ r & s \end{pmatrix} \in \Gamma(2)$ as follows:*

$$\Phi_1 \cdot g = \mathbf{e}[\operatorname{Re}((1+i)p + (1-i)s)] \Phi_1, \quad \Phi_2 \cdot g = \mathbf{e}[\operatorname{Re}(r(1-i))] \Phi_2, \quad \Phi_3 \cdot g = \Phi_3.$$

Under the action of T , the function Φ_1 is invariant, and Φ_3 becomes $-\Phi_3$.

Remark 3 *The function Φ_2 is transformed into $(x_2 - x_1)y_1 - (x_2 + x_1)y_2$ by the action of T . This function is not invariant under the action of W but invariant under the action of $\overline{W} = \{\bar{g} \mid g \in W\} = TWT$.*

By Fact 1, we can easily get the following proposition, which is a key to prove Theorem 3.

Proposition 5 *We have*

$$\begin{aligned} \begin{pmatrix} y_1 \\ y_2 \end{pmatrix} \cdot g_1 &= \begin{pmatrix} 1 & 0 \\ 0 & -1 \end{pmatrix} \begin{pmatrix} y_1 \\ y_2 \end{pmatrix}, & \begin{pmatrix} z_1 \\ z_2 \end{pmatrix} \cdot g_1 &= \begin{pmatrix} 1 & 0 \\ 0 & 1 \end{pmatrix} \begin{pmatrix} z_1 \\ z_2 \end{pmatrix}, \\ \begin{pmatrix} y_1 \\ y_2 \end{pmatrix} \cdot g_2 &= \begin{pmatrix} 0 & 1 \\ 1 & 0 \end{pmatrix} \begin{pmatrix} y_1 \\ y_2 \end{pmatrix}, & \begin{pmatrix} z_1 \\ z_2 \end{pmatrix} \cdot g_2 &= \begin{pmatrix} 0 & 1 \\ -1 & 0 \end{pmatrix} \begin{pmatrix} z_1 \\ z_2 \end{pmatrix}. \end{aligned}$$

By the action of $g = I_2 + 2 \begin{pmatrix} p & q \\ r & s \end{pmatrix} \in \Gamma(2)$, the functions y_1, y_2, z_1 and z_2 change as

$$\begin{aligned} y_1 \cdot g &= \mathbf{e}[\operatorname{Re}(r(1-i))]y_1, & z_1 \cdot g &= \mathbf{e}[\operatorname{Re}(r)]z_1, \\ y_2 \cdot g &= \mathbf{e}[\operatorname{Re}(r(1-i))]y_2, & z_2 \cdot g &= \mathbf{e}[\operatorname{Re}((1+i)p + r + (1-i)s)]z_2. \end{aligned}$$

By the action of elements T , $\gamma_1 = \begin{pmatrix} 1 & 0 \\ 2 & 1 \end{pmatrix}$, $\gamma_2 = \begin{pmatrix} -1 & 0 \\ 2 & 1 \end{pmatrix}$ and $\gamma_3 = \begin{pmatrix} -1 & 0 \\ 0 & 1 \end{pmatrix}$ in $\Gamma^T(2)$, the signs of y_1, y_2, z_1, z_2 change as follows:

	T	γ_1	γ_2	γ_3
y_1	+	-	-	+
y_2	-	-	-	+
z_1	+	-	-	+
z_2	+	-	+	-

Proof of Theorem 3. Proposition 5 implies that the product $z_1 z_2$ is invariant under the action of g_1 and that its sign changes by the action of g_2 . Proposition 3 implies the same for x_3 . Thus $\Phi_1 = x_3 z_1 z_2$ is invariant under the action of W .

Remark 2(2) and Proposition 5 show that $(x_2 - x_1)y_1$ and $(x_2 + x_1)y_2$ are invariant under the action of g_1 and that they are interchanged by the action of g_2 . Thus their fundamental symmetric polynomials Φ_2 and Φ_3 are invariant under the action of W .

Proposition 5 leads to transformation formulas for Φ_1, Φ_2 and Φ_3 with respect to $\Gamma^T(2)$, since x_1, x_2, x_3 are invariant under the action of $\Gamma^T(2)$. q.e.d.

Remark 4 *Representatives of $S\Gamma_0(1+i)/W$ can be given by $\{I_2, \gamma_1, \gamma_2, \gamma_3\}$. The elements $[z \mapsto -z + 1], [z \mapsto z + 1]$ and $[z \mapsto -z]$ appeared in §4.1 are equivalent to γ_1, γ_2 and γ_3 modulo W , respectively. These can be verified by using Theorem 5.*

7.2 Isotropy subgroups

Let Iso_j be the subgroup of $\Lambda = S\Gamma_0^T(1+i)$ consisting of elements which leave Φ_j invariant.

Theorem 4 *We have*

$$S\Gamma_0(1+i) = \operatorname{Iso}_3, \quad \check{W} = \operatorname{Iso}_1 \cap \operatorname{Iso}_3, \quad W = \operatorname{Iso}_1 \cap \operatorname{Iso}_2 \cap \operatorname{Iso}_3,$$

$$[\check{W} : W] = [\check{W} : \overline{W}] = [W : \hat{W}] = [\overline{W} : \hat{W}] = 2,$$

where $\check{W} = \langle W, \overline{W} \rangle$ and $\hat{W} = W \cap \overline{W}$. The Whitehead-link-complement group W is a normal subgroup of $ST_0(1+i)$; the quotient group $ST_0(1+i)/W$ is isomorphic to $\mathbb{Z}_2 \times \mathbb{Z}_2$.

Remark 5 (1) The square of any element of $ST_0(1+i)$ belongs to W .
(2) The Whitehead-link-complement group W is not a normal subgroup of Λ , since $TWT = \overline{W} \neq W$.

Proof. We first show that $ST_0(1+i) = \text{Iso}_3$. Note that the group $ST_0(1+i)$ is generated by W and $\Gamma(2)$. Theorem 3 shows that Φ_3 is invariant under the action of W and $\Gamma(2)$. Thus we have $ST_0(1+i) \subset \text{Iso}_3$. Theorem 3 also shows that $\Phi_3 \cdot T = -\Phi_3$, which means that $T \notin \text{Iso}_3$. Since $[\Lambda : ST_0(1+i)] = 2$, we have $ST_0(1+i) = \text{Iso}_3$.

We next show that $W = \text{Iso}_1 \cap \text{Iso}_2 \cap \text{Iso}_3$. It is clear that $W \subset \text{Iso}_1 \cap \text{Iso}_2 \cap \text{Iso}_3$. By Theorem 3, only the signs of Φ_1 and Φ_2 change by the action of $ST_0(1+i) = \text{Iso}_3$, we have $[\text{Iso}_3 : \text{Iso}_1 \cap \text{Iso}_3] = 2$ and $[\text{Iso}_3 : \text{Iso}_2 \cap \text{Iso}_3] = 2$. Since the element $\begin{pmatrix} 1 & \\ & -1 \end{pmatrix}$ belongs to Iso_2 but not to Iso_1 , we have

$$[\text{Iso}_3 : \text{Iso}_1 \cap \text{Iso}_2 \cap \text{Iso}_3] = 4.$$

The fact $[ST_0(1+i) : W] = 4$ shows that W is equal to $\text{Iso}_1 \cap \text{Iso}_2 \cap \text{Iso}_3$.

Since W is a subgroup of $ST_0(1+i)$ consisting of elements keeping Φ_1 and Φ_2 invariant (only the signs of Φ_1 and Φ_2 change by the action of $ST_0(1+i)$), W is a normal subgroup of $ST_0(1+i)$ with $ST_0(1+i)/W \simeq \mathbb{Z}_2^2$.

We finally show that $W = \text{Iso}_1 \cap \text{Iso}_3$. Since $\overline{W} = TWT$ and Φ_1 is invariant under the actions of W and T by Theorem 3, we have $\overline{W} \subset \text{Iso}_1$. And we have $\overline{W} \subset ST_0(1+i) = \text{Iso}_3$. Thus $\check{W} \subset \text{Iso}_1 \cap \text{Iso}_3$. Since

$$\overline{W} \ni \overline{g_2} = \begin{pmatrix} 1 & 0 \\ 1-i & 1 \end{pmatrix} = g_2^{-1} \begin{pmatrix} 1 & 0 \\ 2 & 1 \end{pmatrix},$$

we have $\Phi_2 \cdot \overline{g_2} = -\Phi_2$, which implies $\overline{g_2} \notin W$ and $\check{W} \not\supseteq W$. Thus we have

$$ST_0(1+i) = \text{Iso}_3 \supseteq \text{Iso}_1 \cap \text{Iso}_3 \supset \check{W} \not\supseteq W.$$

The fact $[ST_0(1+i) : W] = 4$ shows that

$$\text{Iso}_1 \cap \text{Iso}_3 = \check{W}, \quad [\check{W} : W] = 2.$$

Now it is clear that $[\check{W} : \overline{W}] = [W : \hat{W}] = [\overline{W} : \hat{W}] = 2$. q.e.d.

Proposition 6 The functions $(x_2 - x_1)y_1$ and $(x_2 + x_1)y_2$ are invariant under the action of $\hat{W} = W \cap \overline{W}$. The group \hat{W} is a normal subgroup of Λ of index 16.

Proof. The function Φ_2 is the sum of these two functions, which are invariant under the action of W . The function $\Phi_2 \cdot T$ is the difference of these functions, which are invariant under the action of \overline{W} . Thus $\Phi_2 + \Phi_2 \cdot T$ and $\Phi_2 - \Phi_2 \cdot T$ are invariant under the action of \hat{W} .

For $g \in ST_0(1+i)$, we have seen that $gWg^{-1} = W$, which implies $g\overline{W}g^{-1}$. Thus we have $g\hat{W}g^{-1} = \hat{W}$. On the other hand, we have $TWT = \overline{W}$ and $T\overline{W}T = W$; these imply $T\hat{W}T = \hat{W}$. q.e.d.

Remark 6 *The functions in Proposition 6 give a representation of $ST_0(1+i)$. The representation matrices are*

$$\begin{pmatrix} \pm 1 & 0 \\ 0 & \pm 1 \end{pmatrix}, \quad \begin{pmatrix} 0 & \pm 1 \\ \pm 1 & 0 \end{pmatrix};$$

this shows that the quotient group $ST_0(1+i)/\hat{W}$ is isomorphic to the dihedral group of order eight.

7.3 An arithmetical characterization of the Whitehead-link-complement Group

The Whitehead-link-complement group W is defined as the group generated by two elements g_1 and g_2 . It is hard to decide whether a given 2×2 -matrix is in W . In this subsection, we give a criterion for elements of $SL_2(\mathbb{Z}[i])$ to belong to W . The functions Φ_j play a key role. The main theorem of this subsection is the following.

Theorem 5 *An element $g = \begin{pmatrix} p & q \\ r & s \end{pmatrix} \in ST_0(1+i)$ satisfying $\operatorname{Re}(s) \equiv 1 \pmod{2}$ belongs to $\check{W} = \langle W, \bar{W} \rangle$ if and only if*

$$\frac{\operatorname{Re}(p+s) - \operatorname{Im}(p-s) + ((-1)^{\operatorname{Re}(r)} + 1)\operatorname{Re}(q)}{2} \equiv 1 \pmod{2}, \quad \text{when } q \in (1+i)\mathbb{Z}[i]$$

$$\frac{\operatorname{Re}(p+r+s) + \operatorname{Im}(p+r+s) + ((-1)^{\operatorname{Re}(r)} + 1)\operatorname{Im}(q)}{2} \equiv 0 \pmod{2} \quad \text{otherwise.}$$

The element $g \in \check{W}$ belongs to W if and only if

$$\operatorname{Re}(p+q) + \frac{\operatorname{Re}(r) - (-1)^{\operatorname{Re}(q)+\operatorname{Im}(q)}\operatorname{Im}(r)}{2} \equiv 1 \pmod{2}.$$

The element $g \in W$ belongs to $\hat{W} = W \cap \bar{W}$ if and only if $r \in 2\mathbb{Z}[i]$.

Note that, by multiplying iI_2 , we can always normalize g so that

$$\operatorname{Re}(s) \equiv 1 \pmod{2}. \tag{1}$$

The rest of this subsection is devoted to a proof of this theorem. We study the action of $g \in ST_0(1+i)$ on Φ_1 and Φ_2 . For any element $g \in ST_0(1+i)$, since $r \in (1+i)\mathbb{Z}[i]$ and $\det(g) = \pm 1$, we have $p, s \notin (1+i)\mathbb{Z}[i]$, i.e.,

$$\operatorname{Re}(p) \not\equiv \operatorname{Im}(p) \pmod{2}, \quad \operatorname{Re}(s) \not\equiv \operatorname{Im}(s) \pmod{2}.$$

By Fact 1 (1) and (3) (in §6.1) we may regard

$$(g^*)^{-1} \quad \text{as} \quad \begin{pmatrix} \bar{s} & -\bar{r} \\ -\bar{q} & \bar{p} \end{pmatrix}, \tag{2}$$

when we compute the action of $g \in ST_0(1+i)$ on $\Theta\left(\begin{smallmatrix} a \\ b \end{smallmatrix}\right)$'s with characteristic $b \in \frac{1}{2}\mathbb{Z}[i]^2$.

In order to prove the first statement of theorem, we give some lemmas which can be proved by Fact 1 and straightforward calculations.

Lemma 3 *We have*

$$x_3 \cdot g = \mathbf{e}[\operatorname{Re}(r)]x_3, \quad g = \begin{pmatrix} p & q \\ r & s \end{pmatrix} \in S\Gamma_0(1+i).$$

Lemma 4 *For $g \in S\Gamma_0(1+i)$ satisfying $\operatorname{Re}(s) \equiv 1 \pmod{2}$, the function $z_1 \cdot g$ is given by*

$$\begin{aligned} & \mathbf{e}\left[\frac{\operatorname{Re}(r)}{2}\right]_{z_1}(z, t) & \text{if } r \in 2\mathbb{Z}[i], \\ & -\mathbf{e}\left[\frac{\operatorname{Re}(r+s) + \operatorname{Im}(s)}{2}\right]_{z_2}(z, t) & \text{if } r \notin 2\mathbb{Z}[i]. \end{aligned}$$

Lemma 5 *For $g \in S\Gamma_0(1+i)$ satisfying $\operatorname{Re}(s) \equiv 1 \pmod{2}$, the function $z_2 \cdot g$ is given by*

$$\begin{aligned} & -\mathbf{e}\left[\frac{\operatorname{Re}(p+r+s) - \operatorname{Im}(p-s)}{2} + \operatorname{Re}(q)\right]_{z_2} & \text{if } r \in 2\mathbb{Z}[i], q \in (1+i)\mathbb{Z}[i], \\ & -\mathbf{e}\left[\frac{\operatorname{Re}(p-s) + \operatorname{Im}(p+r+s)}{2} + \operatorname{Im}(q)\right]_{z_2} & \text{if } r \in 2\mathbb{Z}[i], q \notin (1+i)\mathbb{Z}[i], \\ & \mathbf{e}\left[\frac{\operatorname{Re}(p+r) - \operatorname{Im}(p)}{2}\right]_{z_1} & \text{if } r \notin 2\mathbb{Z}[i], q \in (1+i)\mathbb{Z}[i], \\ & \mathbf{e}x\left[\frac{\operatorname{Re}(p) + \operatorname{Im}(p+r)}{2}\right]_{z_1} & \text{if } r \notin 2\mathbb{Z}[i], q \notin (1+i)\mathbb{Z}[i]. \end{aligned}$$

Lemmas 3,4,5 yield the following Proposition.

Proposition 7 *An element $g \in S\Gamma_0(1+i)$ satisfying $\operatorname{Re}(s) \equiv 1 \pmod{2}$ belongs to $\langle W, \overline{W} \rangle = \operatorname{Iso}_1 \cap \operatorname{Iso}_3$ if and only if*

$$\begin{aligned} & \frac{\operatorname{Re}(p+s) - \operatorname{Im}(p-s)}{2} + \operatorname{Re}(q) \equiv 1 \pmod{2} & \text{if } q \in (1+i)\mathbb{Z}[i], r \in 2\mathbb{Z}[i], \\ & \frac{\operatorname{Re}(p+s) - \operatorname{Im}(p-s)}{2} \equiv 1 \pmod{2} & \text{if } q \in (1+i)\mathbb{Z}[i], r \notin 2\mathbb{Z}[i], \\ & \frac{\operatorname{Re}(p+r+s) + \operatorname{Im}(p+r+s)}{2} + \operatorname{Im}(q) \equiv 0 \pmod{2} & \text{if } q \notin (1+i)\mathbb{Z}[i], r \in 2\mathbb{Z}[i], \\ & \frac{\operatorname{Re}(p+r+s) + \operatorname{Im}(p+r+s)}{2} \equiv 0 \pmod{2} & \text{if } q \notin (1+i)\mathbb{Z}[i], r \notin 2\mathbb{Z}[i]. \end{aligned}$$

This proposition yields the first statement of Theorem 5.

We next give a necessary and sufficient condition for $g \in S\Gamma_0(1+i)$ to belong to $\operatorname{Iso}_2 \cap \operatorname{Iso}_3$. Fact 1 and straightforward calculations imply the following.

Lemma 6 For an element $g \in ST_0(1+i)$, if $q \in (1+i)\mathbb{Z}[i]$ then

$$x_2 \cdot g = \mathbf{e}[\operatorname{Re}(q)]x_2, \quad x_1 \cdot g = \mathbf{e}[\operatorname{Re}(p+q+r+s)]x_1,$$

if $q \notin (1+i)\mathbb{Z}[i]$ then

$$x_2 \cdot g = \mathbf{e}[\operatorname{Re}(p+q)]x_1, \quad x_1 \cdot g = \mathbf{e}[\operatorname{Re}(q+s)]x_2.$$

Lemma 6 yields the following.

Lemma 7

$$\begin{pmatrix} x_2 - x_1 \\ x_2 + x_1 \end{pmatrix} \cdot g = A \begin{pmatrix} x_2 - x_1 \\ x_2 + x_1 \end{pmatrix}, \quad g = \begin{pmatrix} p & q \\ r & s \end{pmatrix} \in ST_0(1+i),$$

where 2×2 matrix A is given by

$$\begin{aligned} & \begin{pmatrix} 1 & \\ & 1 \end{pmatrix} \quad \text{if } q \in (1+i)\mathbb{Z}[i], \operatorname{Re}(q) \in 2\mathbb{Z}, \quad \operatorname{Re}(p+q+r+s) \in 2\mathbb{Z}, \\ - & \begin{pmatrix} 1 & \\ & 1 \end{pmatrix} \quad \text{if } q \in (1+i)\mathbb{Z}[i], \operatorname{Re}(q) \notin 2\mathbb{Z}, \quad \operatorname{Re}(p+q+r+s) \notin 2\mathbb{Z}, \\ & \begin{pmatrix} & 1 \\ 1 & \end{pmatrix} \quad \text{if } q \in (1+i)\mathbb{Z}[i], \operatorname{Re}(q) \in 2\mathbb{Z}, \quad \operatorname{Re}(p+q+r+s) \notin 2\mathbb{Z}, \\ - & \begin{pmatrix} & 1 \\ 1 & \end{pmatrix} \quad \text{if } q \in (1+i)\mathbb{Z}[i], \operatorname{Re}(q) \notin 2\mathbb{Z}, \quad \operatorname{Re}(p+q+r+s) \in 2\mathbb{Z}, \\ & \begin{pmatrix} 1 & \\ & -1 \end{pmatrix} \quad \text{if } q \notin (1+i)\mathbb{Z}[i], \operatorname{Re}(p+q) \notin 2\mathbb{Z}, \operatorname{Re}(q+s) \notin 2\mathbb{Z}, \\ - & \begin{pmatrix} 1 & \\ & -1 \end{pmatrix} \quad \text{if } q \notin (1+i)\mathbb{Z}[i], \operatorname{Re}(p+q) \in 2\mathbb{Z}, \operatorname{Re}(q+s) \in 2\mathbb{Z}, \\ & \begin{pmatrix} & -1 \\ 1 & \end{pmatrix} \quad \text{if } q \notin (1+i)\mathbb{Z}[i], \operatorname{Re}(p+q) \notin 2\mathbb{Z}, \operatorname{Re}(q+s) \in 2\mathbb{Z}, \\ - & \begin{pmatrix} & -1 \\ 1 & \end{pmatrix} \quad \text{if } q \notin (1+i)\mathbb{Z}[i], \operatorname{Re}(p+q) \in 2\mathbb{Z}, \operatorname{Re}(q+s) \notin 2\mathbb{Z}. \end{aligned}$$

Fact 1 and straightforward calculations imply the following.

Lemma 8 By the action of an element $g \in ST_0(1+i)$ satisfying $\operatorname{Re}(s) \equiv 1 \pmod{2}$, y_1 is transformed into

$$\mathbf{e}\left[\frac{\operatorname{Re}(r) + \operatorname{Im}(r)}{2}\right]y_1 \quad \text{if } r \in 2\mathbb{Z}[i], \quad -\mathbf{e}\left[\frac{\operatorname{Re}(r) + \operatorname{Im}(r)}{2}\right]y_2 \quad \text{if } r \notin 2\mathbb{Z}[i],$$

and y_2 is transformed into

$$\begin{aligned} & -\mathbf{e}\left[\operatorname{Re}(p) + \frac{\operatorname{Re}(r) + \operatorname{Im}(r)}{2}\right]y_2 \quad \text{if } r \in 2\mathbb{Z}[i], \quad q \in (1+i)\mathbb{Z}[i], \\ - & \mathbf{e}\left[\operatorname{Im}(p) + \frac{-\operatorname{Re}(r) + \operatorname{Im}(r)}{2}\right]y_2 \quad \text{if } r \in 2\mathbb{Z}[i], \quad q \notin (1+i)\mathbb{Z}[i], \\ & \mathbf{e}\left[\operatorname{Re}(p) + \frac{\operatorname{Re}(r) + \operatorname{Im}(r)}{2}\right]y_1 \quad \text{if } r \notin 2\mathbb{Z}[i], \quad q \in (1+i)\mathbb{Z}[i], \\ & \mathbf{e}\left[\operatorname{Im}(p) + \frac{-\operatorname{Re}(r) + \operatorname{Im}(r)}{2}\right]y_1 \quad \text{if } r \notin 2\mathbb{Z}[i], \quad q \notin (1+i)\mathbb{Z}[i]. \end{aligned}$$

Lemma 8 implies the following Lemma.

Lemma 9

$$\begin{pmatrix} y_1 \\ y_2 \end{pmatrix} \cdot g = A \begin{pmatrix} y_1 \\ y_2 \end{pmatrix}, \quad g = \begin{pmatrix} p & q \\ r & s \end{pmatrix} \in ST_0(1+i), \quad \operatorname{Re}(s) \equiv 1 \pmod{2},$$

where 2×2 matrix A is given by

$$\begin{aligned} & \begin{pmatrix} 1 & \\ & 1 \end{pmatrix} \text{ if } r \in 2(1+i)\mathbb{Z}[i], & P \notin 2\mathbb{Z}, \\ - & \begin{pmatrix} 1 & \\ & 1 \end{pmatrix} \text{ if } r \notin 2(1+i)\mathbb{Z}[i], \quad r \in 2\mathbb{Z}[i], & P \notin 2\mathbb{Z}, \\ & \begin{pmatrix} 1 & \\ & 1 \end{pmatrix} \text{ if } r \notin 2\mathbb{Z}[i], \quad \frac{\operatorname{Re}(r)+\operatorname{Im}(r)}{2} \notin 2\mathbb{Z}, \quad P + \frac{\varepsilon\operatorname{Re}(r)+\operatorname{Im}(r)}{2} \in 2\mathbb{Z}, \\ - & \begin{pmatrix} 1 & \\ & 1 \end{pmatrix} \text{ if } r \notin 2\mathbb{Z}[i], \quad \frac{\operatorname{Re}(r)+\operatorname{Im}(r)}{2} \in 2\mathbb{Z}, \quad P + \frac{\varepsilon\operatorname{Re}(r)+\operatorname{Im}(r)}{2} \notin 2\mathbb{Z}, \\ & \begin{pmatrix} 1 & \\ & -1 \end{pmatrix} \text{ if } r \in 2(1+i)\mathbb{Z}[i], & P \in 2\mathbb{Z}, \\ - & \begin{pmatrix} 1 & \\ & -1 \end{pmatrix} \text{ if } r \notin 2(1+i)\mathbb{Z}[i], \quad r \in 2\mathbb{Z}[i], & P \in 2\mathbb{Z}, \\ & \begin{pmatrix} 1 & \\ & -1 \end{pmatrix} \text{ if } r \notin 2\mathbb{Z}[i], \quad \frac{\operatorname{Re}(r)+\operatorname{Im}(r)}{2} \in 2\mathbb{Z}, \quad P + \frac{\varepsilon\operatorname{Re}(r)+\operatorname{Im}(r)}{2} \in 2\mathbb{Z}, \\ - & \begin{pmatrix} 1 & \\ & -1 \end{pmatrix} \text{ if } r \notin 2\mathbb{Z}[i], \quad \frac{\operatorname{Re}(r)+\operatorname{Im}(r)}{2} \notin 2\mathbb{Z}, \quad P + \frac{\varepsilon\operatorname{Re}(r)+\operatorname{Im}(r)}{2} \notin 2\mathbb{Z}, \end{aligned}$$

where $\varepsilon = (-1)^{\operatorname{Re}(q)+\operatorname{Im}(q)}$ and $P = \operatorname{Re}(p+q) + \operatorname{Im}(q)$.

Proposition 8 *An element $g \in ST_0(1+i)$ satisfying $\operatorname{Re}(s) \equiv 1 \pmod{2}$ belongs to Iso_2 if and only if*

$$\operatorname{Re}(p+q) + \frac{\operatorname{Re}(r) - (-1)^{\operatorname{Re}(q)+\operatorname{Im}(q)}\operatorname{Im}(r)}{2} \equiv 1 \pmod{2}.$$

Proof. Since only the sign of Φ_2 changes by the action of $g \in ST_0(1+i)$, if $\begin{pmatrix} x_2-x_1 \\ x_2+x_1 \end{pmatrix}$ is transformed into $A \begin{pmatrix} x_2-x_1 \\ x_2+x_1 \end{pmatrix}$ by the action of g then $\begin{pmatrix} y_1 \\ y_2 \end{pmatrix}$ is transformed into $\pm A \begin{pmatrix} y_1 \\ y_2 \end{pmatrix}$ by the action of g , where $A = \begin{pmatrix} \pm 1 & \\ & \pm 1 \end{pmatrix}$, $\begin{pmatrix} \pm 1 & \\ & \pm 1 \end{pmatrix}$ in Lemmas 7 and 9. Thus $g \in ST_0(1+i)$ belongs to Iso_2 if and only if the sign of the transformation matrix A for the action of g on $\begin{pmatrix} x_2-x_1 \\ x_2+x_1 \end{pmatrix}$ coincides with that on $\begin{pmatrix} y_1 \\ y_2 \end{pmatrix}$.

(1) the case $A = \pm \begin{pmatrix} 1 & \\ & 1 \end{pmatrix}$.

By Lemma 7, $g \in ST_0(1+i)$ satisfies

$$q \in (1+i)\mathbb{Z}[i], \quad \operatorname{Re}(q) + \operatorname{Re}(p+q+r+s) \in 2\mathbb{Z},$$

i.e.,

$$\operatorname{Re}(q) + \operatorname{Im}(q) \equiv 0 \pmod{2}, \quad \operatorname{Re}(p+r) \equiv 1 \pmod{2}.$$

By Lemma 9, we have

$$r \in 2\mathbb{Z}[i], \quad P = \operatorname{Re}(p+q) + \operatorname{Im}(q) \notin 2\mathbb{Z}.$$

The coincident condition for the signs is

$$\operatorname{Re}(q) \equiv \frac{\operatorname{Re}(r) + \operatorname{Im}(r)}{2} \equiv \frac{\operatorname{Re}(r) + \operatorname{Im}(r)}{2} - \operatorname{Re}(p+r) + 1 \pmod{2}.$$

Thus we have

$$\operatorname{Re}(p+q) + \frac{\operatorname{Re}(r) - \operatorname{Im}(r)}{2} \equiv 1 \pmod{2}.$$

(2) the case $A = \pm \begin{pmatrix} & 1 \\ 1 & \end{pmatrix}$.

By Lemma 7, $g \in S\Gamma_0(1+i)$ satisfies

$$q \in (1+i)\mathbb{Z}[i], \quad \operatorname{Re}(q) + \operatorname{Re}(p+q+r+s) \notin 2\mathbb{Z},$$

i.e.,

$$\operatorname{Re}(q) + \operatorname{Im}(q) \equiv 0 \pmod{2}, \quad \operatorname{Re}(p+r) \equiv 0 \pmod{2}.$$

By Lemma 9, we have $r \notin 2\mathbb{Z}[i]$ and

$$\begin{aligned} & \frac{\operatorname{Re}(r) + \operatorname{Im}(r)}{2} + P + \frac{\varepsilon \operatorname{Re}(r) + \operatorname{Im}(r)}{2} \\ &= \operatorname{Re}(p+q) + \operatorname{Im}(q+r) + \frac{(1 + (-1)^{\operatorname{Re}(q)+\operatorname{Im}(q)})\operatorname{Re}(r)}{2} \\ &\equiv \operatorname{Re}(p+r) + \operatorname{Im}(r) \equiv \operatorname{Re}(p) \equiv 1 \pmod{2}. \end{aligned}$$

The coincident condition for the signs is

$$\operatorname{Re}(q) \equiv \frac{\operatorname{Re}(r) + \operatorname{Im}(r)}{2} + 1 \equiv \frac{\operatorname{Re}(r) + \operatorname{Im}(r)}{2} - \operatorname{Re}(p+r) + 1 \pmod{2}.$$

Thus we have

$$\operatorname{Re}(p+q) + \frac{\operatorname{Re}(r) - \operatorname{Im}(r)}{2} \equiv 1 \pmod{2}.$$

(3) the case $A = \pm \begin{pmatrix} 1 & \\ & -1 \end{pmatrix}$.

By Lemma 7, $g \in S\Gamma_0(1+i)$ satisfies

$$q \notin (1+i)\mathbb{Z}[i], \quad \operatorname{Re}(p+q) + \operatorname{Re}(q+s) \in 2\mathbb{Z},$$

i.e.,

$$\operatorname{Re}(q) + \operatorname{Im}(q) \equiv 1 \pmod{2}, \quad \operatorname{Re}(p) \equiv 1 \pmod{2}.$$

By Lemma 9, we have

$$r \in 2\mathbb{Z}[i], \quad P = \operatorname{Re}(p+q) + \operatorname{Im}(q) \in 2\mathbb{Z}.$$

The coincident condition for the signs is

$$\operatorname{Re}(p+q) + 1 \equiv \frac{\operatorname{Re}(r) + \operatorname{Im}(r)}{2} \pmod{2}.$$

(4) the case $A = \pm \begin{pmatrix} & -1 \\ 1 & \end{pmatrix}$.

By Lemma 7, $g \in S\Gamma_0(1+i)$ satisfies

$$q \notin (1+i)\mathbb{Z}[i], \quad \operatorname{Re}(p+q) + \operatorname{Re}(q+s) \notin 2\mathbb{Z},$$

i.e.,

$$\operatorname{Re}(q) + \operatorname{Im}(q) \equiv 1 \pmod{2}, \quad \operatorname{Re}(p) \equiv 0 \pmod{2}.$$

By Lemma 9, we have $r \notin 2\mathbb{Z}[i]$ and

$$\begin{aligned} & \frac{\operatorname{Re}(r) + \operatorname{Im}(r)}{2} + P + \frac{\varepsilon \operatorname{Re}(r) + \operatorname{Im}(r)}{2} \\ & \equiv \operatorname{Re}(p+q) + \operatorname{Im}(q+r) \equiv \operatorname{Re}(p) \equiv 0 \pmod{2}. \end{aligned}$$

The coincident condition for the signs is

$$\operatorname{Re}(p+q) + 1 \equiv \frac{\operatorname{Re}(r) + \operatorname{Im}(r)}{2} \pmod{2}. \quad \text{q.e.d.}$$

This proposition yields the second statement of Theorem 5. We show the last statement of Theorem 5. The element $g \in W$ satisfying $\operatorname{Re}(s) \equiv 1 \pmod{2}$ belongs to \hat{W} if and only if the transformation matrix A for the action of g on $\begin{pmatrix} x_2 - x_1 \\ x_2 + x_1 \end{pmatrix}$ is

$$\pm \begin{pmatrix} 1 & \\ & 1 \end{pmatrix} \quad \text{or} \quad \pm \begin{pmatrix} 1 & \\ & -1 \end{pmatrix}.$$

Thus we have the condition $r \in 2\mathbb{Z}[i]$, which is kept under the multiplication iI_2 to g .

8 Embeddings of the quotient spaces

In the previous section, we constructed automorphic functions Φ_1 , Φ_2 and Φ_3 for W . The map

$$\mathbb{H}^3 \ni (z, t) \mapsto (\lambda_1, \dots, \lambda_4, \frac{\Phi_1}{x_0^3}, \frac{\Phi_2}{x_0^2}, \frac{\Phi_3}{x_0^4})$$

induces a map $\mathbb{H}^3/W \rightarrow \mathbb{R}^7$, which is generically injective but not quite. In §8.1, we construct, for each $j = 1, 2, 3$, automorphic functions f_{j1}, f_{j2}, \dots for W such that their common zero is $F_k \cup F_l$, where $\{j, k, l\} = \{1, 2, 3\}$. Here the curves $F_1, F_2, F_3 \subset \mathbb{H}^3$ are defined as the W -orbits of the fixed loci of the transformations $\gamma_1, \gamma_2, \gamma_3$, respectively (§4.2, Remark 4 in §7.1). These functions give, in §§8.2, 8.3 and 8.4, embeddings of the quotient spaces $\mathbb{H}^3/S\Gamma_0(1+i)$, \mathbb{H}^3/\hat{W} and \mathbb{H}^3/W , respectively.

8.1 Automorphic functions for W vanishing along F_j

We use W -invariant functions as follows:

$$\begin{aligned}
f_{00} &= (x_2^2 - x_1^2)y_1y_2 = \Phi_3, \\
f_{01} &= (x_2^2 - x_1^2)z_1z_2z_3z_4, \\
f_{11} &= x_3z_1z_2 = \Phi_1, \\
f_{12} &= x_1x_2z_1z_2, \\
f_{13} &= x_3(x_2^2 - x_1^2)z_3z_4, \\
f_{14} &= x_1x_2(x_2^2 - x_1^2)z_3z_4, \\
f_{20} &= (x_2 - x_1)z_2z_3 + (x_2 + x_1)z_1z_4, \\
f_{21} &= z_1z_2\{(x_2 - x_1)z_1z_3 + (x_2 + x_1)z_2z_4\}, \\
f_{22} &= (x_2^2 - x_1^2)\{(x_2 - x_1)z_1z_4 + (x_2 + x_1)z_2z_3\}, \\
f_{30} &= (x_2 - x_1)y_1 + (x_2 + x_1)y_2 = \Phi_2, \\
f_{31} &= (x_2 - x_1)z_1z_3 - (x_2 + x_1)z_2z_4, \\
f_{32} &= z_3z_4\{-(x_2 - x_1)z_1z_4 + (x_2 + x_1)z_2z_3\},
\end{aligned}$$

where

$$z_3 = \Theta \begin{bmatrix} 0, i \\ 1, 0 \end{bmatrix}, \quad z_4 = \Theta \begin{bmatrix} 1+i, i \\ 1, 1+i \end{bmatrix}.$$

Set

$$\mathfrak{f}_{ij} = f_{ij}/x_0^{\deg(f_{ij})},$$

where $\deg(f)$ denotes the total degree of the polynomial f with respect to x_i, y_j, z_k .

Proposition 9 *The functions f_{jp} are invariant under the action of W . These functions change the signs by the actions of γ_1, γ_2 and γ_3 as in the table*

	γ_1	γ_2	γ_3
f_{0j}	+	+	+
f_{1j}	+	-	-
f_{2j}	-	+	-
f_{3j}	-	-	+

This Proposition can be obtained by Proposition 5 and the following lemma.

Lemma 10 *We have*

$$\begin{pmatrix} z_3 \\ z_4 \end{pmatrix} \cdot g_1 = \begin{pmatrix} 1 & 0 \\ 0 & -1 \end{pmatrix} \begin{pmatrix} z_3 \\ z_4 \end{pmatrix}, \quad \begin{pmatrix} z_3 \\ z_4 \end{pmatrix} \cdot g_2 = \begin{pmatrix} 0 & -1 \\ 1 & 0 \end{pmatrix} \begin{pmatrix} z_3 \\ z_4 \end{pmatrix}.$$

By the action of $T, \gamma_1, \gamma_2, \gamma_3 \in \Gamma^T(2)$, the signs of z_3, z_4 change as

	T	γ_1	γ_2	γ_3
z_3	+	+	+	+
z_4	-	+	-	-

Proposition 2 and Fact 3 yield the following proposition, which is a key to study the zero locus of f_{jp} .

Proposition 10 *We have*

$$\begin{aligned}
4z_1^2 &= 4\Theta \begin{bmatrix} 0, 1 \\ 1, 0 \end{bmatrix}^2 \\
&= 2\Theta \begin{bmatrix} 0, 0 \\ 0, 0 \end{bmatrix} \Theta \begin{bmatrix} 0, 1+i \\ 1+i, 0 \end{bmatrix} + 2\Theta \begin{bmatrix} 0, 1+i \\ 0, 0 \end{bmatrix} \Theta \begin{bmatrix} 0, 0 \\ 1+i, 0 \end{bmatrix} - 2\Theta \begin{bmatrix} 1+i, 1+i \\ 1+i, 1+i \end{bmatrix} \Theta \begin{bmatrix} 1+i, 0 \\ 0, 1+i \end{bmatrix} \\
&= (x_0 + x_1 + x_2 + x_3)(x_0 - x_1 - x_2 + x_3),
\end{aligned}$$

$$\begin{aligned}
4z_2^2 &= 4\Theta \begin{bmatrix} 1+i, 1 \\ 1, 1+i \end{bmatrix}^2 \\
&= -2\Theta \begin{bmatrix} 0, 0 \\ 0, 0 \end{bmatrix} \Theta \begin{bmatrix} 0, 1+i \\ 1+i, 0 \end{bmatrix} + 2\Theta \begin{bmatrix} 0, 1+i \\ 0, 0 \end{bmatrix} \Theta \begin{bmatrix} 0, 0 \\ 1+i, 0 \end{bmatrix} + 2\Theta \begin{bmatrix} 1+i, 1+i \\ 1+i, 1+i \end{bmatrix} \Theta \begin{bmatrix} 1+i, 0 \\ 0, 1+i \end{bmatrix} \\
&= (x_0 + x_1 - x_2 - x_3)(x_0 - x_1 + x_2 - x_3)
\end{aligned}$$

$$\begin{aligned}
4z_3^2 &= 4\Theta \begin{bmatrix} 0, i \\ 1, 0 \end{bmatrix}^2 \\
&= 2\Theta \begin{bmatrix} 0, 0 \\ 0, 0 \end{bmatrix} \Theta \begin{bmatrix} 0, 1+i \\ 1+i, 0 \end{bmatrix} + 2\Theta \begin{bmatrix} 0, 1+i \\ 0, 0 \end{bmatrix} \Theta \begin{bmatrix} 0, 0 \\ 1+i, 0 \end{bmatrix} + 2\Theta \begin{bmatrix} 1+i, 1+i \\ 1+i, 1+i \end{bmatrix} \Theta \begin{bmatrix} 1+i, 0 \\ 0, 1+i \end{bmatrix} \\
&= (x_0 + x_1 - x_2 + x_3)(x_0 - x_1 + x_2 + x_3),
\end{aligned}$$

$$\begin{aligned}
4z_4^2 &= 4\Theta \begin{bmatrix} 1+i, i \\ 1, 1+i \end{bmatrix}^2 \\
&= -2\Theta \begin{bmatrix} 0, 0 \\ 0, 0 \end{bmatrix} \Theta \begin{bmatrix} 0, 1+i \\ 1+i, 0 \end{bmatrix} + 2\Theta \begin{bmatrix} 0, 1+i \\ 0, 0 \end{bmatrix} \Theta \begin{bmatrix} 0, 0 \\ 1+i, 0 \end{bmatrix} - 2\Theta \begin{bmatrix} 1+i, 1+i \\ 1+i, 1+i \end{bmatrix} \Theta \begin{bmatrix} 1+i, 0 \\ 0, 1+i \end{bmatrix} \\
&= (x_0 + x_1 + x_2 - x_3)(x_0 - x_1 - x_2 - x_3).
\end{aligned}$$

Remark 7 *The functions $z_1^2 + z_2^2$, $z_1^2 z_2^2$, $z_3^2 + z_4^2$, $z_1^2 z_2^2$, $z_1^2 z_3^2 + z_2^2 z_4^2$ and $z_1^2 z_4^2 + z_2^2 z_3^2$ are invariant under the action of Λ . They can be expressed in terms of $\lambda_1, \dots, \lambda_4$ and x_0 :*

$$\begin{aligned}
z_1^2 + z_2^2 &= z_3^2 + z_4^2 = \frac{1}{2}(x_0^2 - \lambda_1 + \lambda_3), \\
z_1^2 z_2^2 &= \frac{1}{16}(\lambda_3^2 - 2(x_0^2 + \lambda_1)\lambda_3 + 8\lambda_4 x_0 + x_0^4 - 2x_0^2 \lambda_1 + \lambda_1^2 - 4\lambda_2), \\
z_3^2 z_4^2 &= \frac{1}{16}(\lambda_3^2 - 2(x_0^2 + \lambda_1)\lambda_3 - 8\lambda_4 x_0 + x_0^4 - 2x_0^2 \lambda_1 + \lambda_1^2 - 4\lambda_2), \\
z_1^2 z_3^2 + z_2^2 z_4^2 &= \frac{1}{8}(\lambda_3^2 + 2(3x_0^2 - \lambda_1)\lambda_3 + x_0^4 - 2x_0^2 \lambda_1 + \lambda_1^2 - 4\lambda_2), \\
z_1^2 z_4^2 + z_2^2 z_3^2 &= \frac{1}{8}(\lambda_3^2 - 2(x_0^2 + \lambda_1)\lambda_3 + x_0^4 - 2x_0^2 \lambda_1 + \lambda_1^2 + 4\lambda_2).
\end{aligned}$$

Remark 8 *Proposition 10 implies*

$$\begin{aligned}
z_1^2 - z_2^2 &= x_0 x_3 - x_1 x_2, \\
z_3^2 - z_4^2 &= x_0 x_3 + x_1 x_2, \\
z_3^2 - z_1^2 &= z_2^2 - z_4^2 = x_1 x_2, \\
z_1^2 - z_4^2 &= z_3^2 - z_2^2 = x_0 x_3,
\end{aligned}$$

$$\begin{aligned} z_1^2 z_3^2 - z_2^2 z_4^2 &= \frac{1}{2} x_0 x_3 (x_0^2 - x_1^2 - x_2^2 + x_3^2), \\ -z_1^2 z_4^2 + z_2^2 z_3^2 &= \frac{1}{2} x_1 x_2 (x_0^2 - x_1^2 - x_2^2 + x_3^2). \end{aligned}$$

These functions are invariant under the action of g_1 and their signs change by the action g_2 . The product of x_3 (resp. $x_1 x_2$) and each of these is invariant under the action Λ and can be expressed in terms of $\lambda_1, \dots, \lambda_4$ and x_0 .

Theorem 6 *The analytic sets V_1, V_2 and V_3 of the ideals*

$$I_1 = \langle f_{11}, f_{12}, f_{13}, f_{14} \rangle, \quad I_2 = \langle f_{21}, f_{22} \rangle, \quad I_3 = \langle f_{31}, f_{32} \rangle$$

are (set-theoretically) equal to $F_2 \cup F_3, F_1 \cup F_3$ and $F_1 \cup F_2$, respectively.

Corollary 2 *The analytic set V_{jk} of the ideals $\langle I_j, I_k \rangle$ is set-theoretically equal to F_l for $\{j, k, l\} = \{1, 2, 3\}$.*

Proof of Theorem 6. Since the sets F_j are the fixed loci of γ_j modulo W and f_{kl} are invariant under the action of W , it is clear that $V_j \supset F_k \cup F_l$ for $\{j, k, l\} = \{1, 2, 3\}$. We first show $V_1 \subset F_2 \cup F_3$. Since we have

$$\begin{aligned} f_{11}^2 &= x_3^2 \prod_{\substack{\varepsilon_1 \varepsilon_2 \varepsilon_3 = 1 \\ \varepsilon_1, \varepsilon_2, \varepsilon_3 = \pm 1}} (x_0 + \varepsilon_1 x_1 + \varepsilon_2 x_2 + \varepsilon_3 x_3), \\ f_{12}^2 &= x_1^2 x_2^2 \prod_{\substack{\varepsilon_1 \varepsilon_2 \varepsilon_3 = 1 \\ \varepsilon_1, \varepsilon_2, \varepsilon_3 = \pm 1}} (x_0 + \varepsilon_1 x_1 + \varepsilon_2 x_2 + \varepsilon_3 x_3), \\ f_{13}^2 &= x_3^2 (x_2^2 - x_1^2)^2 \prod_{\substack{\varepsilon_1 \varepsilon_2 \varepsilon_3 = -1 \\ \varepsilon_1, \varepsilon_2, \varepsilon_3 = \pm 1}} (x_0 + \varepsilon_1 x_1 + \varepsilon_2 x_2 + \varepsilon_3 x_3), \\ f_{14}^2 &= x_1^2 x_2^2 (x_2^2 - x_1^2)^2 \prod_{\substack{\varepsilon_1 \varepsilon_2 \varepsilon_3 = -1 \\ \varepsilon_1, \varepsilon_2, \varepsilon_3 = \pm 1}} (x_0 + \varepsilon_1 x_1 + \varepsilon_2 x_2 + \varepsilon_3 x_3), \end{aligned}$$

they are invariant also under the action of $\Gamma^T(2)$. So we express the common zeros of them in terms of x_j . The twelve edges of the octahedron

$$Oct = \{x = [x_0, x_1, x_2, x_3] \in \mathbb{P}^3(\mathbb{R}) \mid |x_1| + |x_2| + |x_3| \leq x_0\},$$

(recall that $\mathbb{H}^3/\Gamma^T(2)$ is realized as Oct minus the vertices, in Theorem 1) and the segments

$$\begin{aligned} &\{x \in Oct \mid x_1 = x_3 = 0\}, \quad \{x \in Oct \mid x_2 = x_3 = 0\}, \\ &\{x \in Oct \mid x_0 + x_1 + x_2 + x_3 = x_1 - x_2 = 0\}, \\ &\{x \in Oct \mid x_0 - x_1 - x_2 + x_3 = x_1 - x_2 = 0\}, \\ &\{x \in Oct \mid x_0 + x_1 - x_2 - x_3 = x_1 + x_2 = 0\}, \\ &\{x \in Oct \mid x_0 - x_1 + x_2 - x_3 = x_1 + x_2 = 0\} \end{aligned}$$

come into the game. Fact 2 shows that V_1 is the union of the inverse images of ϑ , which coincides with $F_2 \cup F_3$.

We next show $V_3 \subset F_1 \cup F_2$. Since we have

$$\begin{aligned} f_{31} \cdot T &= (x_2 - x_1)z_1z_3 + (x_2 + x_1)z_2z_4, \\ f_{32} \cdot T &= z_3z_4\{(x_2 - x_1)z_1z_4 + (x_2 + x_1)z_2z_3\}, \end{aligned}$$

the products

$$\begin{aligned} \tilde{f}_{31} &= (f_{31})(f_{31} \cdot T) = (x_2 - x_1)^2z_1^2z_3^2 - (x_2 + x_1)^2z_2^2z_4^2, \\ \tilde{f}_{32} &= (f_{32})(f_{32} \cdot T) = z_3^2z_4^2\{(x_2 - x_1)^2z_1^2z_4^2 - (x_2 + x_1)^2z_2^2z_3^2\}, \end{aligned}$$

are invariant under the action of $\Gamma^T(2)$. We express the common zero of \tilde{f}_{31} and \tilde{f}_{32} in terms of x_j . By Proposition 10, we have

$$\begin{aligned} \tilde{f}_{31} &= -\frac{1}{4} \left[x_1x_2x_3^4 + 2x_1x_2(3x_0^2 - x_1^2 - x_2^2)x_3^2 - 2x_0(x_2^2 + x_1^2)(x_0^2 - x_1^2 - x_2^2 + x_3^2)x_3 \right. \\ &\quad \left. + x_1x_2(x_1 + x_0 - x_2)(x_0 + x_1 + x_2)(x_2 - x_1 + x_0)(x_0 - x_1 - x_2) \right], \\ \tilde{f}_{32} &= -\frac{1}{64} x_1x_2(x_0^2 + x_1^2 - x_2^2 - x_3^2)(x_0^2 - x_1^2 + x_2^2 - x_3^2) \\ &\quad \times \prod_{\varepsilon_1\varepsilon_2\varepsilon_3=-1} (x_0 + \varepsilon_1x_1 + \varepsilon_2x_2 + \varepsilon_3x_3). \end{aligned}$$

Thus V_3 is a subset of the union of the common zeroes of \tilde{f}_{31} and the factors of \tilde{f}_{32} . We study the restriction of \tilde{f}_{31} on the algebraic set of each factor of \tilde{f}_{32} . In the octahedron Oct , the factors $x_0^2 + x_1^2 - x_2^2 - x_3^2$ and $x_0^2 - x_1^2 + x_2^2 - x_3^2$ vanish only on $[x_0, x_1, x_2, x_3] = [1, 0, 0, \pm 1]$, $[1, 0, \pm 1, 0]$ and $[1, 0, 0, \pm 1]$, $[1, \pm 1, 0, 0]$, respectively. The functions \tilde{f}_{31} vanishes on these points. On $x_j = 0$, \tilde{f}_{31} reduces to

$$\frac{1}{2}x_0x_k^2x_3(x_0^2 - x_k^2 + x_3^2),$$

where $\{j, k\} = \{1, 2\}$. On $x_0 + \varepsilon_1x_1 + \varepsilon_2x_2 + \varepsilon_3x_3 = 0$ ($\varepsilon_1\varepsilon_2\varepsilon_3 = -1$), \tilde{f}_{31} reduces to

$$\varepsilon_3x_0(x_1 - \varepsilon_3x_2)^2(x_0 + \varepsilon_1x_1)(x_0 + \varepsilon_2x_2)(x_0 + \varepsilon_1x_1 + \varepsilon_2x_2).$$

Thus the common zero of \tilde{f}_{31} and \tilde{f}_{32} in the fundamental domain FD of \mathbb{H}^3/W in Figure 2 is the union of $F_1 \cup F_2$ and the geodesic joining $(z, t) = (0, 0)$, $(-1 + i, 0)$ through $\square = (\frac{-1+i}{\sqrt{2}}, \frac{1}{2})$ which is the inverse image of ϑ of $\{[x_0, x_1, x_2, x_3] \in Oct \mid x_1 = x_3 = 0\}$. We have only to show that f_{31} does not vanish on $\vartheta^{-1}\{[x_0, x_1, x_2, x_3] \in Oct \mid x_1 = x_3 = 0\}$.

Since

$$(z_1z_2z_3z_4)^2 = \prod_{\varepsilon_1, \varepsilon_2, \varepsilon_3 = \pm 1} (x_0 + \varepsilon_1x_1 + \varepsilon_2x_2 + \varepsilon_3x_3),$$

the function $z_1z_2z_3z_4$ never vanish on the interior of FD . Thus we have $z_1z_2z_3z_4 > 0$ or $z_1z_2z_3z_4 < 0$ on the interior of FD . Since f_{31} reduces to $-x_1(z_1z_3 + z_2z_4)$ on the set $\{[x_0, x_1, x_2, x_3] \in Oct \mid x_2 = x_3 = 0\}$ and f_{31} vanishes on this set, the sign of z_1z_3 is different from that of z_2z_4 , which implies $z_1z_2z_3z_4 < 0$ the interior of FD . On the other hand, f_{31} reduces to $x_2(z_1z_3 - z_2z_4)$ on the set $\{[x_0, x_1, x_2, x_3] \in Oct \mid x_1 = x_3 = 0\}$. Since the sign of z_1z_3 is different from that of z_2z_4 on the interior of

FD , $z_1z_3 - z_2z_4$ never vanish on the interior of FD . Hence f_{31} never vanishes on the interior of $\{[x_0, x_1, x_2, x_3] \in Oct \mid x_1 = x_3 = 0, x_2 \neq 0\}$.

We finally show $V_2 \subset F_1 \cup F_3$. Since we have

$$\begin{aligned} f_{21} \cdot T &= z_1z_2\{(x_2 - x_1)z_1z_3 - (x_2 + x_1)z_2z_4\}, \\ f_{22} \cdot T &= (x_2^2 - x_1^2)\{-(x_2 - x_1)z_1z_4 + (x_2 + x_1)z_2z_3\}, \end{aligned}$$

the products

$$\begin{aligned} \tilde{f}_{21} &= (f_{21})(f_{21} \cdot T) = z_1^2z_2^2\{(x_2 - x_1)^2z_1^2z_3^2 - (x_2 + x_1)^2z_2^2z_4^2\}, \\ \tilde{f}_{22} &= (f_{22})(f_{22} \cdot T) = (x_2^2 - x_1^2)^2\{-(x_2 - x_1)^2z_1^2z_4^2 + (x_2 + x_1)^2z_2^2z_3^2\}, \end{aligned}$$

are invariant under the action of $\Gamma^T(2)$. We express the common zero of them in terms of x_j . By proposition 10, we have

$$\begin{aligned} \tilde{f}_{21} &= \frac{1}{16} \tilde{f}_{31} \prod_{\varepsilon_1, \varepsilon_2, \varepsilon_3 = \pm 1}^{\varepsilon_1 \varepsilon_2 \varepsilon_3 = 1} (x_0 + \varepsilon_1 x_1 + \varepsilon_2 x_2 + \varepsilon_3 x_3) \\ \tilde{f}_{22} &= \frac{1}{4} (x_2^2 - x_1^2)^2 x_1 x_2 (x_0^2 + x_1^2 - x_2^2 - x_3^2) (x_0^2 - x_1^2 + x_2^2 - x_3^2). \end{aligned}$$

Thus V_2 is a subset of the union of the common zeroes of \tilde{f}_{21} and the factors of \tilde{f}_{22} . We study the restriction of \tilde{f}_{21} on the algebraic set of each factor of \tilde{f}_{22} . Since we have studied the restriction of \tilde{f}_{31} on the algebraic set of each factor of \tilde{f}_{32} , we have only to consider the restriction of

$$z_1^2 z_2^2 = \frac{1}{16} \prod_{\varepsilon_1, \varepsilon_2, \varepsilon_3 = \pm 1}^{\varepsilon_1 \varepsilon_2 \varepsilon_3 = 1} (x_0 + \varepsilon_1 x_1 + \varepsilon_2 x_2 + \varepsilon_3 x_3)$$

on the algebraic set of each factor of \tilde{f}_{22} and that of \tilde{f}_{21} on the sets $x_1 \pm x_2 = 0$. We can see that the common zero of \tilde{f}_{21} and \tilde{f}_{22} in FD is the union of $F_1 \cup F_3$ and the geodesic joining $(z, t) = (-1, 0)$, $(i, 0)$ through $\square = (\frac{-1+i}{\sqrt{2}}, \frac{1}{2})$ which is the inverse image of ϑ of $\{[x_0, x_1, x_2, x_3] \in Oct \mid x_2 = x_3 = 0\}$. In order to show that f_{21} does not vanish on $\vartheta^{-1}\{[x_0, x_1, x_2, x_3] \in Oct \mid x_2 = x_3 = 0\}$, follow the proof of the non-vanishing of f_{31} on $\vartheta^{-1}\{[x_0, x_1, x_2, x_3] \in Oct \mid x_1 = x_3 = 0\}$. q.e.d.

8.2 An Embedding of $\mathbb{H}^3/S\Gamma_0(1+i)$

Theorem 7 *The map*

$$\varphi_0 : \mathbb{H}^3/S\Gamma_0(1+i) \ni (z, t) \mapsto (\lambda_1, \dots, \lambda_4, f_{01}) \in \mathbb{R}^5$$

is injective, where $f_{01} = f_{01}/x_0^6$. Its image $\text{Image}(\varphi_0)$ is determined by the image $\text{Image}(\lambda)$ under $\lambda : \mathbb{H}^3 \ni (z, t) \mapsto (\lambda_1, \dots, \lambda_4)$ and the relation

$$\begin{aligned} 256f_{01}^2 &= (x_2^2 - x_1^2)^2 \prod_{\varepsilon_1, \varepsilon_2, \varepsilon_3 = \pm 1} (x_0 + \varepsilon_1 x_1 + \varepsilon_2 x_2 + \varepsilon_3 x_3) \\ &= (\lambda_1^2 - 4\lambda_2) \prod_{\varepsilon_3 = \pm 1} (\lambda_3^2 - 2(x_0^2 + \lambda_1)\lambda_3 + \varepsilon_3 8x_0\lambda_4 + x_0^4 - 2x_0^2\lambda_1 + \lambda_1^2 - 4\lambda_2), \end{aligned}$$

as a double cover of $\text{Image}(\lambda)$ branching along its boundary.

If we replace f_{01} by f_{00} , the map is injective as well, but the expression of the image becomes a bit more complicated for f_{00} .

Proof. Proposition 10 and Remark 7 give the expression f_{01}^2 in terms of $\lambda_1, \dots, \lambda_4$ and x_0 .

Since the function f_{01} is invariant under the action of $ST_0(1+i)$ and changes its sign by the action of T , the map φ_0 induces a double cover

$$\text{Image}(\varphi) \ni (\lambda_1, \dots, \lambda_4, f_{01}) \longmapsto (\lambda_1, \dots, \lambda_4) \in \text{Image}(\lambda),$$

which ramifies along the zero locus of f_{01} :

$$\begin{array}{ccc} \mathbb{H}^3/ST_0(1+i) & \xrightarrow{\varphi_0} & \text{Image}(\varphi_0) \\ \downarrow & & \downarrow \\ \mathbb{H}^3/\Lambda & \xrightarrow{\lambda} & \text{Image}(\lambda) \end{array}$$

The natural map (studied in §5.2 and §5.3) $\mathbb{H}^3/ST_0(1+i) \rightarrow \mathbb{H}^3/\Lambda$ is a double cover of a 3-ball (minus two points) by a 3-sphere (minus two points) branching along the boundary of the 3-ball. Thus we have only to show that the function f_{01} vanishes only along the boundary $a \cup b \cup c \cup d$ of the 3-ball \mathbb{H}^3/Λ (see Theorem 2).

By remark 2 (2), we have $(x_2 + x_1) \cdot (g_1T) = -(x_2 + x_1)$. Thus $x_2 + x_1$ vanishes on the mirror $\{(z, t) \in \mathbb{H}^3 \mid \text{Im}(z) = \frac{1}{2}\}$ of the reflection g_1T . By Theorem 1, $x_2 + x_1$ vanishes only on d in the fundamental domain in Figure 10(left). Similarly, $x_2 - x_1$ vanishes only on the mirror c in the fundamental domain in Figure 10(left).

By Theorem 1 and Proposition 10, $z_1 z_2 z_3 z_4$ vanishes only on $a \cup b$ in the fundamental domain in Figure 10(left). q.e.d.

We briefly observe the image $\text{Image}(\varphi_0)$. The two cusps ∞ and 0 , and the points \square and $\bar{\square}$ (defined in §4.1) are mapped to

$$\bar{\infty} := (0, 0, 1, 0, 0), \quad \bar{0} := (1, 0, 0, 0, 0), \quad \bar{\square} := (0, 0, 0, 0, 0), \quad \bar{\square} := \left(\frac{1}{2}, \frac{1}{16}, 0, 0, 0\right).$$

The images \bar{F}_1, \bar{F}_2 and \bar{F}_3 of the axes F_1, F_2 and F_3 (see §4.2) are union of curves joining these points:

$$\begin{array}{l} \bar{F}_1 : \bar{\square} \text{---} \bar{\infty} \text{---} \bar{\square}, \quad \bar{F}_2 : \bar{\square} \text{---} \bar{0} \text{---} \bar{\square}, \\ \bar{F}_3 : \bar{\square} \text{---} \bar{0} \text{---} \bar{\infty} \text{---} \bar{\square}. \end{array}$$

Four of these curves come to each cusp. We parameterize these curves ($0 \leq t \leq 1$) and present them as follows:

$$\begin{array}{l} \bar{F}_1 \begin{cases} \bar{\square} \longrightarrow \bar{\infty} & (0, 0, (1-t)^2, 0, 0) & \text{as } t \rightarrow 0, \\ \bar{\square} \longrightarrow \bar{\infty} & \left(\frac{t^2}{2}, \frac{t^4}{16}, (1-t)^2, -\frac{t^2(1-t)}{4}, 0\right) & \text{as } t \rightarrow 0, \end{cases} \\ \bar{F}_3 \begin{cases} \bar{0} \longrightarrow \bar{\infty} & (t^2, 0, (1-t)^2, 0, 0) & \text{as } t \rightarrow 0, \\ \bar{\square} \longrightarrow \bar{\infty} & \left(\frac{t^2}{2}, \frac{t^4}{16}, (1-t)^2, \frac{t^2(1-t)}{4}, 0\right) & \text{as } t \rightarrow 0, \end{cases} \end{array}$$

and

$$\begin{array}{l} \bar{F}_2 \begin{cases} \bar{\square} \longrightarrow \bar{0} & ((1-t)^2, 0, 0, 0, (1-t)^2 t^2 (2-t)^2) & \text{as } t \rightarrow 0, \\ \bar{\square} \longrightarrow \bar{0} & \left(\frac{t^2}{4}, +(1-\frac{t}{2})^2, \frac{t^2}{4}(1-\frac{t}{2})^2, 0, 0, 0\right) & \text{as } t \rightarrow 0, \end{cases} \\ \bar{F}_3 \begin{cases} \bar{\square} \longrightarrow \bar{0} & ((1-t)^2, 0, 0, 0, -(1-t)^2 t^2 (2-t)^2) & \text{as } t \rightarrow 0, \\ \bar{\infty} \longrightarrow \bar{0} & ((1-t)^2, 0, t^2, 0, 0) & \text{as } t \rightarrow 0. \end{cases} \end{array}$$

These curves can be illustrated as in Figure 12. Each of the two cusps $\bar{\infty}$ and $\bar{0}$ is shown as a hole. These holes can be deformed into sausages as in Figure 13. Note that this is just the orbifold $\mathbb{H}^3/S\Gamma_0(1+i)$ shown in Figure 8(right), if we replace the curves L_∞ and L_0 by their tubular neighborhoods.

Recall that four of the orbifold-singular-loci stick into each cusp-hole, of which boundary is a 2-sphere, and that the double cover of a 2-sphere branching at four points is a torus.

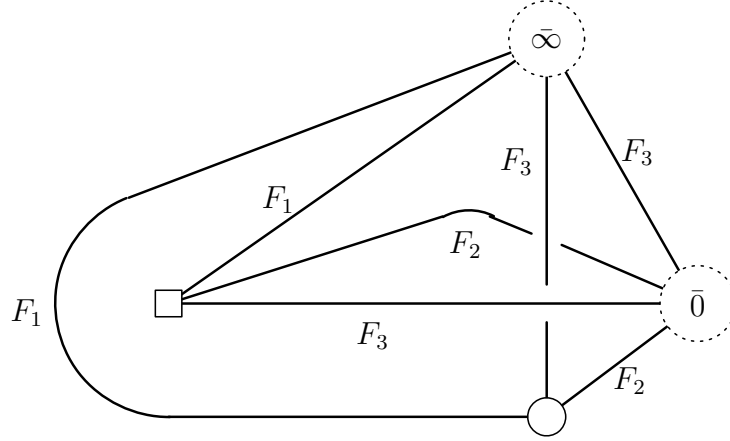

Figure 12: Orbifold singularities in $\text{Image}(\varphi_0)$ and the cusps $\bar{\infty}$ and $\bar{0}$

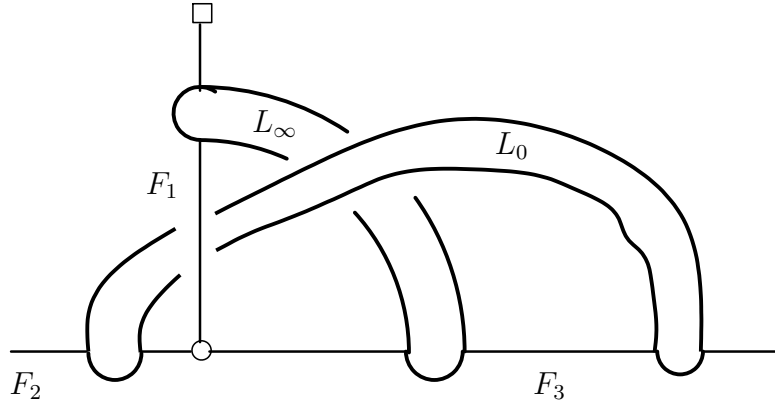

Figure 13: The cusp-holes are deformed into two sausages

8.3 An Embedding of \mathbb{H}^3/\check{W}

Theorem 8 *The map*

$$\varphi_1 : \mathbb{H}^3/\check{W} \ni (z, t) \mapsto (\varphi_0, f_{11}, \dots, f_{14}) \in \mathbb{R}^9$$

is injective, where $f_{ij} = f_{ij}/x_0^{\deg(f_{ij})}$. The products $f_{1p}f_{1q}$ ($1 \leq p \leq q \leq 4$) can be expressed as polynomials of $x_0, \lambda_1, \dots, \lambda_4$ and f_{01} . The image $\text{Image}(\varphi_0)$ together with these relations determines the image $\text{Image}(\varphi_1)$ under the map φ_1 .

Proof. Each f_{1p} is invariant under the action of \check{W} and its sign changes under the action of $ST_0(1+i)/\check{W}$. By Proposition 10 and Remark 7, $f_{11}^2, \dots, f_{14}^2$ and $f_{11}f_{12}, f_{13}f_{14}$ can be expressed in terms of λ_j and x_0 ; they are invariant under the action of Λ . The product $f_{1p}f_{1q}$ ($p = 1, 2, q = 3, 4$) is invariant under the action of $ST_0(1+i)$ by Proposition 9 and they can be expressed in terms of x_0, λ_j , and f_{01} . Thus if one of the values of f_{11}, \dots, f_{14} is not zero at a point $(z, t) \in \mathbb{H}^3$, then this non-zero value together with the image $\varphi_0(z, t)$ determines the vector $(f_{11}(z, t), \dots, f_{14}(z, t))$. Thus we have the commutative diagram

$$\begin{array}{ccc} \mathbb{H}^3/\check{W} & \xrightarrow{\varphi_1} & \text{Image}(\varphi_1) \\ \downarrow & & \downarrow \\ \mathbb{H}^3/ST_0(1+i) & \xrightarrow{\varphi_0} & \text{Image}(\varphi_0) \end{array}$$

of φ_0, φ_1 and the two (vertical) double covers. Since φ_0 is an isomorphism and the left vertical map ramifies exactly along $F_2 \cup F_3$ (§5.1, §5.2), the map φ_1 is injective thanks to Theorem 6. q.e.d.

Though the embedding dimension is too high to see the shape of the image directly unfortunately, the theorem above and the argument in §5 asserts the following: The boundary of a small neighborhood of the cusp $\varphi_1(0)$ is a torus, which is the double cover of that of the cusp $\varphi_0(0)$; note that two F_2 -curves and two F_3 -curves stick into $\varphi_0(0)$. The boundary of a small neighborhood of the cusp $\varphi_1(\infty)$ remains to be a 2-sphere; note that two F_1 -curves and two F_3 -curves stick into $\varphi_0(\infty)$, and that four F_1 -curves stick into $\varphi_1(\infty)$.

Topologically, the sausage L_0 in Figure 13 (and Figure 8(right)) is covered by a doughnut, a tubular neighborhood of the curve L_0 in Figure 7(right).

8.4 An Embedding of \mathbb{H}^3/W

Theorem 9 *The map*

$$\varphi : \mathbb{H}^3/W \ni (z, t) \mapsto (\varphi_1, f_{21}, f_{22}, f_{31}, f_{32}) \in \mathbb{R}^{13}$$

is injective, where $f_{ij} = f_{ij}/x_0^{\deg(f_{ij})}$. The products $f_{2q}f_{2r}, f_{3q}f_{3r}$ and $f_{1p}f_{2q}f_{3r}$ ($p = 1, \dots, 4, q, r = 1, 2$) can be expressed as polynomials of $x_0, \lambda_1, \dots, \lambda_4$ and f_{01} . The image $\text{Image}(\varphi_1)$ together with these relations determines the image $\text{Image}(\varphi)$ under the map φ .

Proof. By Proposition 10, the products $f_{2q}f_{2r}, f_{3q}f_{3r}$ and $f_{1p}f_{2q}f_{3r}$ ($p = 1, \dots, 4, q, r = 1, 2$) are invariant under the action of $ST_0(1+i)$ by Proposition 9. They can be expressed in terms of $x_0, \lambda_1, \dots, \lambda_4$ and f_{01} . For example,

$$\begin{aligned} f_{22}^2 &= (\lambda_1^2 - 4\lambda_2)\{(x_1^2 + x_2^2)(z_1^2 z_4^2 + z_2^2 z_3^2) - 2x_1 x_2 (z_1^2 z_4^2 - z_2^2 z_3^2) + 2f_{01}\}, \\ f_{31}^2 &= (x_1^2 + x_2^2)(z_1^2 z_3^2 + z_2^2 z_4^2) - 2x_1 x_2 (z_1^2 z_3^2 - z_2^2 z_4^2) - 2f_{01}, \\ f_{31}f_{32} &= z_3^2 z_4^2 \{2x_1 x_2 (z_1^2 - z_2^2) - (x_1^2 + x_2^2)(z_1^2 + z_2^2)\} + (z_3^2 + z_4^2)f_{01}, \\ f_{21}f_{31} &= z_1 z_2 \tilde{f}_{31}, \\ f_{22}f_{31} &= (x_1^2 + x_2^2)(x_0 f_{13} - f_{14}) - 2f_{14}(z_1^2 + z_2^2) + (x_2^2 - x_1^2)^2(x_0 f_{11} + f_{12}), \\ f_{22}f_{32} &= -\frac{1}{64}(x_0^2 + x_1^2 - x_2^2 - x_3^2)(x_0^2 - x_1^2 + x_2^2 - x_3^2)f_{14}; \end{aligned}$$

(Remarks 7 and 8 help us to find these expressions.) So the values of f_{21}^2 , f_{22}^2 , f_{31}^2 and f_{32}^2 at any point in \mathbb{H}^3 are determined by those of $x_0, \lambda_1, \dots, \lambda_4$ and f_{01} . Moreover, if one of the values of f_{21} , f_{22} , f_{31} and f_{32} is not zero at a point $(z, t) \in \mathbb{H}^3$, then this non-zero value together with the image $\varphi_1(z, t)$ determines the vector

$$(f_{21}(z, t), f_{22}(z, t), f_{31}(z, t), f_{32}(z, t)).$$

Thus we have the commutative diagram

$$\begin{array}{ccc} \mathbb{H}^3/W & \xrightarrow{\varphi} & \text{Image}(\varphi) \\ \downarrow & & \downarrow \\ \mathbb{H}^3/\check{W} & \xrightarrow{\varphi_1} & \text{Image}(\varphi_1) \end{array}$$

of φ, φ_1 and the two (vertical) double covers. Since φ_1 is an isomorphism and the left vertical map ramifies exactly along F_1 (§5.1), the map φ is injective thanks to Corollary 2. q.e.d.

Though the embedding dimension is too high to see the shape of the image directly unfortunately, the theorem above and the argument in §5 asserts the following: The boundary of a small neighborhood of the cusp $\varphi(\infty)$ is a torus, which is the double cover of that of the cusp $\varphi_1(\infty)$; recall that four F_1 -curves stick into $\varphi_1(\infty)$. The boundary of a small neighborhood of the cusp $\varphi(0)$ is a torus, which is the unbranched double cover of that of the cusp $\varphi_1(0)$, a torus.

Eventually, the two sausages in Figure 13 (and Figure 8(right)) are covered by two linked doughnuts, tubular neighborhoods of the curves L_0 and L_∞ in Figure 1. Note that, in the (high dimensional) ambient space, the two tori look as if they are not linked, however they are linked in the $\text{Image}(\varphi)$.

References

- [F] E. Freitag, Modulformen zweiten Grades zum rationalen und Gaußschen Zahlkörper, *Sitzungsber. Heidelb. Akad. Wiss.*, **1** (1967), 1–49.
- [MSY] K. Matsumoto, T. Sasaki and M. Yoshida, The monodromy of the period map of a 4-parameter family of K3 surfaces and the Aomoto-Gel'fand hypergeometric function of type (3,6), *Internat. J. of Math.*, **3** (1992), 1–164.
- [M1] K. Matsumoto, Theta functions on the bounded symmetric domain of type $I_{2,2}$ and the period map of 4-parameter family of K3 surfaces, *Math. Ann.*, **295** (1993), 383–408.
- [M2] K. Matsumoto, Algebraic relations among theta functions on the bounded symmetric domain of type $I_{r,r}$, preprint.
- [MY] K. Matsumoto and M. Yoshida, Invariants for some real hyperbolic groups, *Internat. J. of Math.*, **13** (2002), 415–443.
- [T] W. Thurston, *Geometry and Topology of 3-manifolds*, Lecture Notes, Princeton Univ., 1977/78.

- [W] N. Wielenberg, The structure of certain subgroups of the Picard group. *Math. Proc. Cambridge Philos. Soc.* **84** (1978), no. 3, 427–436.
- [Y] M. Yoshida, *Hypergeometric Functions, My Love*, Aspects of Mathematics, E32, Friedr Vieweg & Sohn, Braunschweig, 1997.

Keiji Matsumoto
Department of Mathematics
Hokkaido University
Sapporo 060-0810
Japan
e-mail:matsu@math.sci.hokudai.ac.jp

Haruko Nishi
Department of Mathematics
Kyushu University
Fukuoka 812-8581
Japan
e-mail:nishi@math.kyushu-u.ac.jp

Masaaki YOSHIDA
Department of Mathematics
Kyushu University
Fukuoka 810-8560
Japan
e-mail:myoshida@math.kyushu-u.ac.jp